

Mounting Instructions

Festoon Systems for I-Beams

Program 0350 / 0360 / 0364



Contents

	Page
1 General notes	5
1.1 Information about these installation instructions	5
1.2 Limitation of liability	5
1.3 Copyright	6
1.4 Spare parts	6
1.5 Material defects	6
1.6 Technical support	6
2 Safety instructions	7
2.1 General safety information	7
2.2 Requirements concerning personnel	8
2.2.1 Qualifications	8
2.2.2 Unauthorized personnel	8
2.2.3 Instruction	8
2.3 Personal protective equipment	9
2.4 Intended use	10
2.5 Protective measures to be taken by the operator/user	11
2.6 Particular risks	12
2.7 Behavior in case of accidents and malfunctions	14
3 Technical specifications	15
3.1 General information	15
3.2 Interfaces	15
3.3 Operating conditions	15
3.4 Type plate	16
3.5 Track beam	16
3.5.1 Smoothing of welded track beams	17
3.5.2 Use of even welded track beams	17
3.5.3 Girder joint for non-welded track beams	18
3.5.4 Horizontal deviation of track beams	19
3.5.5 Vertical deviation of track beams	19

Mounting Instructions



Festoon Systems for I-Beams

Program 0350 / 0360 / 0364

3.5.6	Poor horizontal alignment between the crane beam and the track beam	20
3.5.7	Poor vertical alignment between the crane beam and track beam.....	20
4	Product Description and Mode of Operation	21
4.1	Overview of the festoon system	21
4.2	Brief description	22
4.3	Description of assemblies.....	22
4.4	Working and danger areas	26
4.5	Operating modes	27
4.5.1	Automatic operation.....	27
4.5.2	Manual operation.....	27
5	Transport, packaging and storage	28
5.1	Transport	28
5.1.1	Safety instructions for transport.....	28
5.1.2	Transport inspection	28
5.2	Packaging.....	29
5.3	Storage of packed parts	29
6	Installation and commissioning	30
6.1	Safety	30
6.2	Preparation	31
6.3	Installation	31
6.3.1	Mounting a pre-assembled festoon system	32
6.3.2	Mounting a towing clamp	33
6.3.3	Mounting the towing trolley	34
6.3.4	Assembling the festoon	34
6.3.5	Mounting the end clamp	35
6.3.6	Arrangement of round cables	36
6.3.7	Arrangement of flat cables.....	38
6.3.8	Mounting round cable clamps.....	39
6.3.9	Mounting flat cable clamps	41
6.3.10	Mounting the towing rope	41
6.3.11	Damping device	43

Mounting Instructions



Festoon Systems for I-Beams Program 0350 / 0360 / 0364

6.3.12	Adjusting the running gear	45
6.4	Testing and commissioning	46
6.4.1	Commissioning checklist	47
7	Operation	49
7.1	Safety	49
7.2	Function.....	50
8	Maintenance and service	51
8.1	Safety	51
8.2	Maintenance / inspection plan	52
8.2.1	Inspection on deactivated system	53
8.2.2	Inspection of towing ropes and criteria for replacement	54
8.2.3	Inspection on moving system	55
8.2.4	Logging	55
8.2.5	Maintenance of the festoon system	56
8.2.6	Wearing parts	58
8.2.7	Wear limits	58
8.2.8	Repeat inspections	59
8.2.9	Repair	59
9	Troubleshooting	60
10	Disassembly and disposal	61
10.1	Safety	61
10.2	Disassembly	62
10.3	Disposal.....	62
10.4	Documentation for electrical equipment	63
10.5	Spare parts list.....	63
10.6	Product observations	64
11	Final Acceptance Certificate (PFR05-15-02-E).....	66

1 General notes

1.1 Information about these installation instructions

These installation instructions allow the safe, efficient use of the festoon system.

The installation instructions are a component of the festoon system and must be kept in the immediate vicinity of the festoon system and accessible to personnel at all times. Personnel must carefully read and understand these installation instructions before starting any work. The basic prerequisite for safe work is compliance with all safety and operating guidelines in these installation instructions.

Furthermore, local accident protection regulations and general safety regulations apply for the area of use of the festoon system.

Illustrations are provided for basic understanding and may deviate from the actual implementation of the festoon system.

In addition to these installation instructions, the attached instructions for installed components also apply.

1.2 Limitation of liability

All data and information in these installation instructions has been compiled while taking the valid standards and regulations as well as the state-of-the art and our long years of experience and knowledge into consideration.

The manufacturer is in no way liable for damages resulting from:

- Failure to comply with installation instructions
- Improper use
- Employment of untrained personnel
- Unauthorized modifications
- Technical changes
- Use of unauthorized replacement parts or accessories.

The actual scope of delivery may differ from the explanations and illustrations here depending on special implementations, the inclusion of additional order options, or due to the latest technical changes.

The obligations specified in the scope of delivery, the general terms of business, and the delivery terms of the manufacturer apply, along with the legal regulations valid at the time of conclusion of the contract.

All products are subject to technical changes during the process of improvement of characteristics of use and continued development.

Festoon Systems for I-Beams Program 0350 / 0360 / 0364

1.3 Copyright

These installation instructions are subject to copyright and exclusively intended for internal use.

Provision of the installation instructions to third parties, duplications in any form - even in part - as well as the reuse and/or disclosure of their content are not permitted without the written approval of the manufacturer, except for internal use.

Violations will result in the obligation to compensate for damages. Other rights reserved.

1.4 Spare parts



WARNING!

Safety risk due to wrong spare parts!

Wrong or faulty spare parts can impair safety as well as result in damages, malfunctions or complete failure.

→ Use only original spare parts of the manufacturer!

Obtain spare parts from licensed dealers or directly from the manufacturer. See the last page of these operating instructions for the address.

1.5 Material defects

The regulations about material defects are listed in the general terms and conditions of business.

1.6 Technical support

For technical support please contact our staff from the Customer Support Department. See the last page of these operating instructions for contact information.

Our employees are also always interested in new information and experience from use that can be valuable for the improvement of our products.

2 Safety instructions

2.1 General safety information

Safety and hazard information is identified in these installation instructions by symbols. Signal words are used in these safety instructions to indicate the degree of hazard. Always observe safety and hazard information and work carefully to avoid accidents, bodily harm or property damage!



DANGER!

... indicates an immediately hazardous situation, which if not avoided, may result in death or serious injury.



WARNING!

... indicates a possibly hazardous situation, which if not avoided, may result in death or serious injury.



WARNING!

... indicates a possible danger of burning if not avoided.



WARNING!

... indicates a possible danger from electricity, which if not avoided, may result in death or serious injury.



CAUTION!

... indicates a possibly hazardous situation, which if not avoided, may result in moderate or minor injury and property damage.



Tips and recommendations:

... refers to useful tips and recommendations as well as information for efficient and trouble-free operation.

Festoon Systems for I-Beams Program 0350 / 0360 / 0364

2.2 Requirements concerning personnel

2.2.1 Qualifications



Injury due to insufficient qualifications!

Improper use can result in serious injury to person and property.

→ Allow only qualified personnel to carry out all activities!

The following qualifications have been mentioned in these operating instructions for different areas of operation:

- **Trained personnel/operators**
have been instructed by the operator about the tasks assigned to them and the possible hazards resulting from improper use.
- **Qualified specialists**
Due to their technical education, knowledge, and experience as well as knowledge of the applicable specifications, are capable of carrying out the tasks assigned to them and to detect and avoid possible dangers independently.
- Personnel may only be authorized if it can be expected that they carry out their work reliably. Personnel whose reactions are influenced by drugs, alcohol, or medications may not be authorized.
- Locally applicable age and qualification regulations must be followed during selection of personnel.

2.2.2 Unauthorized personnel



Danger due to unauthorized personnel!

Unauthorized personnel who do not meet the requirements described here do not understand the danger in the work area.

- Keep unauthorized persons away from the working area.
- In case of doubt, address the persons and direct them away from the working area.
- Stop work as long as unauthorized persons are in the working area.

2.2.3 Instruction

Before commissioning, the personnel must be instructed by the operator. For better tracking, log the performance of this instruction as follows:

Date	Name	Type of instruction	Instruction given by	Signature

2.3 Personal protective equipment

Always wear: For all work, always wear:



Work safety clothing

is close-fitting work clothing that has a low tearing strength with tight arms and no parts that protrude. It is mostly used as protection from getting caught by moving machine parts.

Do not wear any rings, chains or any other jewelry!



Safety shoes

used to protect from falling heavy parts and slipping on slippery floors.

For special tasks, wear:

When carrying out particular tasks, special safety gear is required. The individual sections of these instructions specify this gear in detail. The following particular safety gear is explained below:



Protective gloves

for the protection of hands from friction, scrapes, stabbing, or deep wounds, as well as from contact with hot surfaces.



Hard hat

for protection from falling and flying parts and materials.



Protective goggles

for eye protection.

Festoon Systems for I-Beams Program 0350 / 0360 / 0364

2.4 Intended use

The festoon system is exclusively designed and built for the intended use described here.

Festoon systems program 0350, 0360 and 0364 are intended for the installation and operation of an electrical supply line for track-based mobile consumers, such as cranes and lifting gears in industrial environment. Other uses are only permitted after written approval by Conductix-Wampfler.



Possible injury resulting from improper use!

Any application that deviates from or goes beyond the intended use described here can result in a hazardous situation.

- The festoon system may only be used as intended.
- Strictly comply with all specifications of these installation and operating instructions.
- Do not use the equipment for any other purpose than described here.

The following use of the festoon system is forbidden. Non-intended use particularly includes the following:

- Using the festoon system with unapproved accessories or accessories not authorized by the manufacturer.
- Operation of the festoon system by untrained personnel.
- Operation of the festoon system when installed on an improper foundation / base.
- Exceeding projected load capacities
- Exceeding projected speeds
- Excessive acceleration
- Use of unsuitable cables
- Operation under conditions other than the agreed environmental and operating conditions (including a change to projected physical location).

Claims of any kind due to damages from improper use are excluded.

The operator bears sole liability for any damages due to unintended use.

2.5 Protective measures to be taken by the operator/user

The festoon system is used in an industrial setting. The operator of the festoon system is thus subject to legal requirements related to workplace safety. In addition to the safety guidelines in these installation instructions, the safety, accident protection, and environmental protection regulations applicable to the place of operation of the festoon system must be followed. This particularly implies that:

- The operator must ensure that the festoon system will only be used for its intended purpose.
- The operator must be informed of applicable workplace safety regulations and carry out a risk assessment to detect additional dangers resulting from the specific working conditions in the place of operation of the festoon system. This must be implemented in the form of operating instructions for the operation of the festoon system.
- For the entire period of use of the festoon system, the operator must check whether the operating instructions prepared correspond to the current state of regulations, and update the operating instructions as needed.
- The operator must clearly regulate and determine responsibilities for installation, operation, troubleshooting, and maintenance.
- The operator must ensure that all employees involved with the festoon system have read and understood these installation instructions. Moreover, the operator must train personnel at regular intervals and inform them of the dangers.
- The operator must provide personnel with the protective gear required.

Furthermore, the operator is responsible for ensuring that the festoon system is always in a technically perfect condition. The following thus apply:

- The operator must ensure that the maintenance schedule described in these installation instructions is followed.
- The operator must regularly have all safety systems checked for functionality and completeness.

2.6 Particular risks

The following section lists residual risks determined based on a risk assessment.

- Follow the safety instructions listed here and the warnings in other sections of these installation instructions in order to reduce health hazards and avoid dangerous situations.



WARNING!

Danger of death due to hanging loads!

When lifting loads, there is a danger of death from falling parts or those swinging out of control.

- Never step under hanging loads.
- Move loads only under supervision.
- Follow the specifications for the attachment points provided.
- Do not attach to projecting machine parts or to eyes on installed components. Be sure the connection elements are firmly seated.
- Use only authorized lifting accessories and connection elements with sufficient load capacity.
- Do not use torn or worn ropes or straps.
- Do not attach ropes or straps to sharp corners and edges, and do not knot or twist them.
- Set down the load when leaving the workplace.



WARNING!

Danger of injury from moving components!

Incautious handling of the festoon system can lead to severe injury or damage to the festoon system.

- Be sure that the festoon system does not start by itself.
- While it is moving, do not reach into moving parts, particularly the interface between the buffer and buffer plate.
- Block off the dangerous area under the system.



DANGER!

Danger of injury due to electric shock!

Danger of severe injury or death from electric current.

- Before working on the festoon system, the system must be disconnected from power using the main switch, and secured against unauthorized, unintentional, and/or erroneous activation.
- In special cases where there is no main switch, the power disconnection must be carried out according to the specifications of the system manufacturer.
- Check parts disconnected from power, then ground and short-circuit them. Insulate neighboring parts that are connected to power.
- Before each commissioning, an insulation test must be carried out in accordance with the local technical standards, guidelines, and law.

Festoon Systems for I-Beams

Program 0350 / 0360 / 0364



WARNING!

Danger of burning!

Danger of burning when using insufficiently dimensioned cables!

→ Always comply with the necessary cross-section of cables.



CAUTION!

Danger of tripping on projecting parts!

When working on the festoon system, there is a risk of tripping.

→ When walking in the work and danger area, be careful of projections and depressions in the floor.
No loose objects may be left on the floor.



WARNING!

Danger of crushing!

When moving the festoon system, there is a danger of crushing limbs between the buffer and buffer plate, as well as between the running gear and the track beam.

→ When the system is moving, do not enter the danger area of the festoon system.



WARNING!

Danger of crushing!

During installation of a festoon system, there is a danger of crushing limbs between the load carrier and the track beam.

→ During installation, do not enter the danger area of the festoon system.



CAUTION!

Trap!

When the festoon system is moving, there is a danger of being trapped within it.

→ When the system is moving, do not enter the danger area of the festoon system.

2.7 Behavior in case of accidents and malfunctions

Measures to be taken in case of accident:

- Secure the location of the accident.
- Take first-aid measures.
- Keep personnel out of the danger area.
- Inform responsible parties at the place of operation.
- Alarm the rescue services.
- Make access ready for rescue vehicles.

Measures to be taken in case of malfunction:

- Secure the work area against entry.
- Involve qualified personnel for fault analysis.
- Involve authorized personnel for maintenance and repair.
- Shut down the system and secure it against unauthorized, unintentional, and/or erroneous activation.
- If injury to person and property can occur during breakdowns then Conductix-Wampfler must be informed immediately.

Mounting Instructions



Festoon Systems for I-Beams Program 0350 / 0360 / 0364

3 Technical specifications

3.1 General information

Designation	Value	Notes
Max. load capacity	125 - 500 kg	Depending on the festoon product line selected
Max. travel speed	160 - 180 m/min	Depending on the festoon product line selected

3.2 Interfaces

Mechanical:

Machine	Part
Load-bearing structure	End clamp, festoon, towing trolley
Towing arm	Towing trolley, towing clamp
Cables	Saddle, cable clamps, cable organizers
Track beam	Load carrier

Electrical, data, and media:

Machine	Part
Switching cabinet	Cables
Media supply	Cables
Consumer	Cables

3.3 Operating conditions

Environment:

Designation	Value	Notes
Temperature range	-30 to +50°C	+80°C in combination with steel rollers
Relative humidity, maximum	90%	100% possible after adaptation
Max. allowed wind speed (operating)	< 21 m/sec	
Max. allowed wind speed (non-operating)	< 33 m/sec	

3.4 Type plate



Fig. 1: Sample type plate

The type plate is on the end clamp and includes the following information:

- Model
- Year of construction
- Order number
- Manufacturer
- Manufacturer address



NOTICE!

Tips and recommendations:

In case of inquiries with regard to the festoon systems, always indicate the data on the type plate.

3.5 Track beam

The operator is basically responsible for ensuring that the track beam is securely fastened as well as checking it for wear, corrosion or defects.

The following procedures are to be observed when installing the track beam:

- In general, track beams are to be protected from corrosion using appropriate measures.
- The running surfaces of the main rollers and the horizontal guide rollers must be clean and free of objects or defects that could damage the rollers (scratches, cracks, holes, uneven segments, etc.).
- If multiple beams are welded together, they must all have the same measurements, shape and positional tolerances.
- The beam flanges are to be aligned with particular care in horizontal and vertical planes.
- Track beams that have been damaged during transport or rolling are not permitted for use.
- Modified areas (from welding, sanding, etc.) on the track beam are to be protected from corrosion with appropriate measures.
- There may be no projecting contours on the sides of the track area or under the track beam.

Festoon Systems for I-Beams

Program 0350 / 0360 / 0364

3.5.1 Smoothing of welded track beams

Bumps and uneven areas on **all sides** of the welded track beams are to be ground smooth for a length of 100 mm.

i
NOTICE!

Required tools and materials:

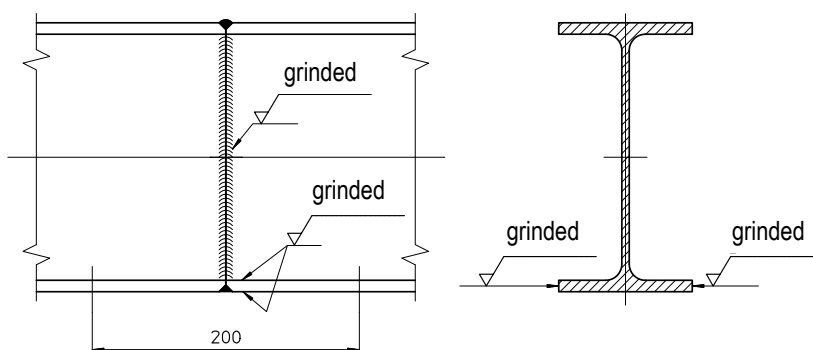

Fig. 2: Smoothing of welded track beams

3.5.2 Use of even welded track beams

Weld seams on the track beams must be **even** at points that could come into contact with the cable trolleys. Mounting elements and suspended objects that could come into contact with the trolleys are not permitted.

No uneven areas, mounting elements, suspended objects, etc.

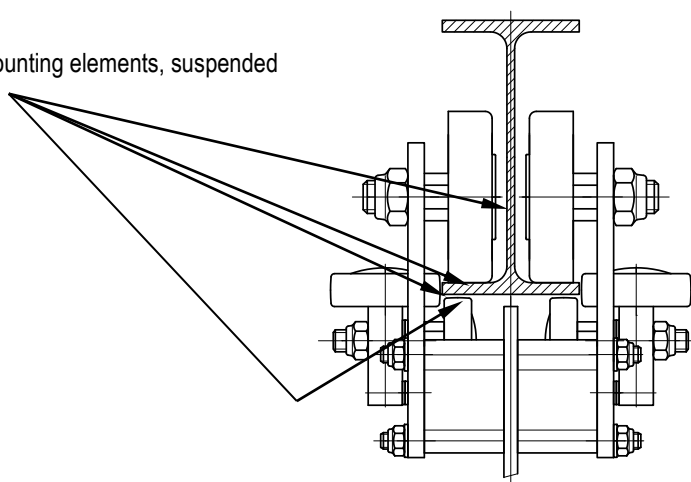

Fig. 3: Use of even welded track beams

Festoon Systems for I-Beams

Program 0350 / 0360 / 0364

3.5.3 Girder joint for non-welded track beams

For non-welded girder joints, the gap between beams may be **at most 8 mm**. The cut is at a **45°** angle.

i
NOTICE!

Required tools and materials:

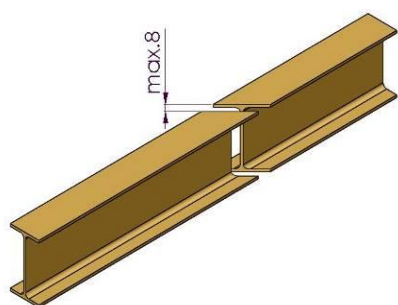

Fig. 4: Girder joint for non-welded track beams

For non-welded girder joints, the horizontal and vertical deviation of the opposing sides of the joint may be **at most 2 mm**. Transitions must be ground smooth within **about 100 mm** of the beginning of the cut. All transitions must be **bevelled and rounded off**.

i
NOTICE!

Required tools and materials:

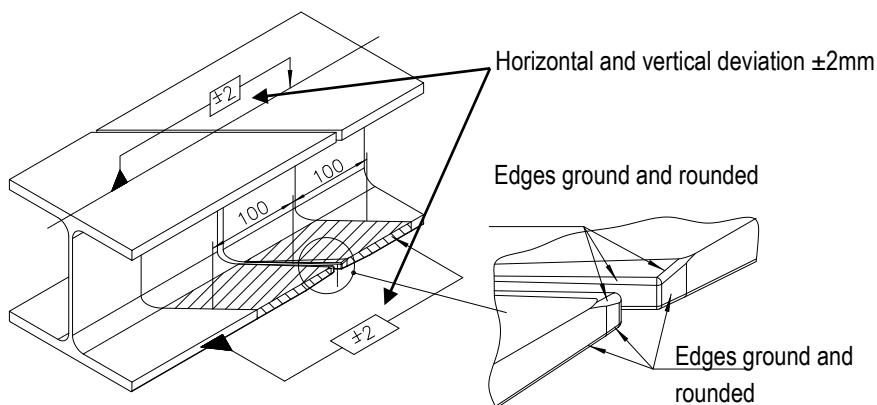

Fig. 5: Girder joint for non-welded track beams

Festoon Systems for I-Beams Program 0350 / 0360 / 0364

3.5.4 Horizontal deviation of track beams

The horizontal deviation over the length of the track beam may not exceed ± 5 mm. For lengths shorter than 2 m, deviation may not exceed ± 2 mm.

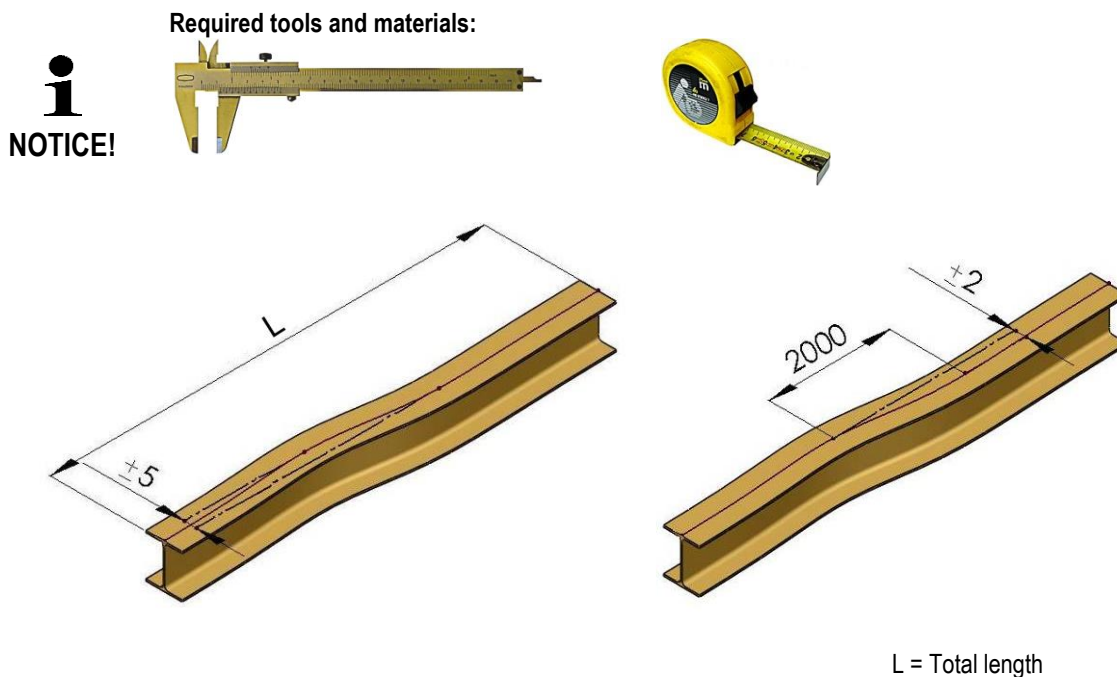

Fig. 6: Horizontal deviation of track beams

3.5.5 Vertical deviation of track beams

The vertical deviation over the length of the track beam may not exceed ± 5 mm. For lengths shorter than 2 m, deviation may not exceed ± 2 mm.

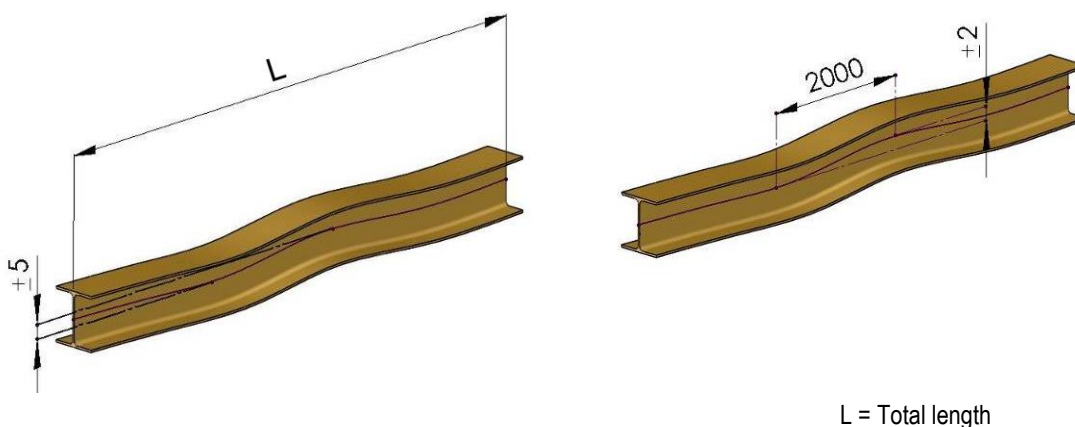

Fig. 7: Vertical deviation of track beams

Festoon Systems for I-Beams

Program 0350 / 0360 / 0364

3.5.6 Poor horizontal alignment between the crane beam and the track beam

The horizontal alignment gap between the crane beam and track beam must not exceed ± 7.5 mm. This tolerance should include a possible alignment deviation of the trolley winch.

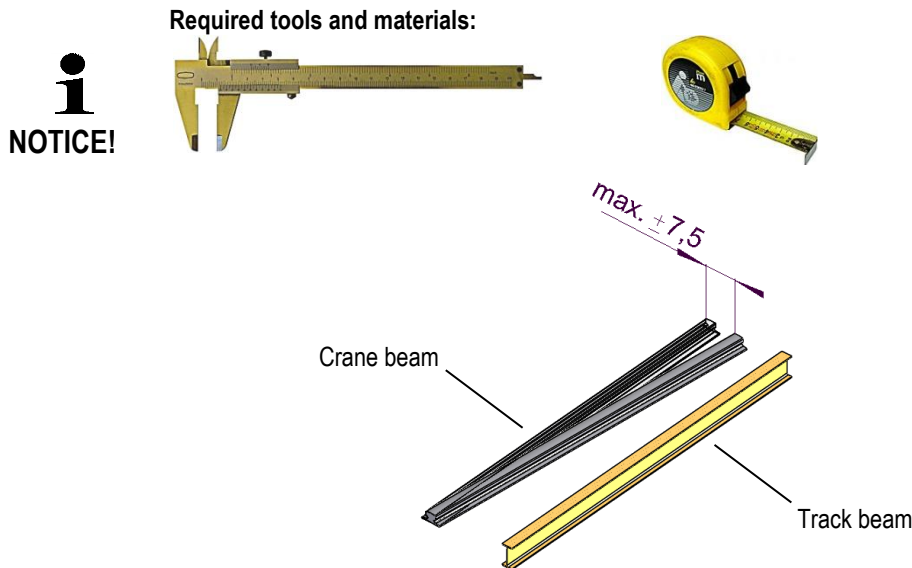

Fig. 8: Poor horizontal alignment between the crane beam and the track beam

3.5.7 Poor vertical alignment between the crane beam and track beam

The vertical alignment gap between the crane beam and track beam must not exceed ± 15 mm. This tolerance should include a possible alignment deviation of the trolley winch.

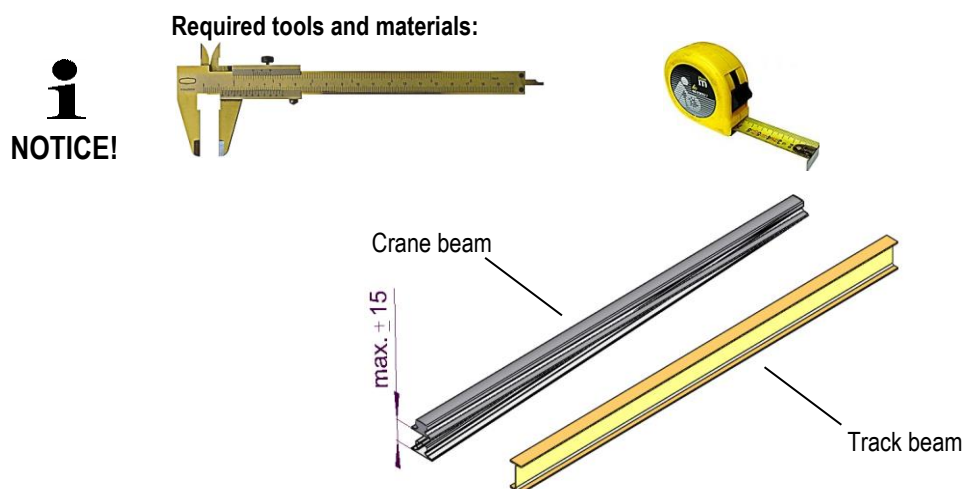

Fig. 9: Poor vertical alignment between the crane beam and track beam

4 Product Description and Mode of Operation

4.1 Overview of the festoon system

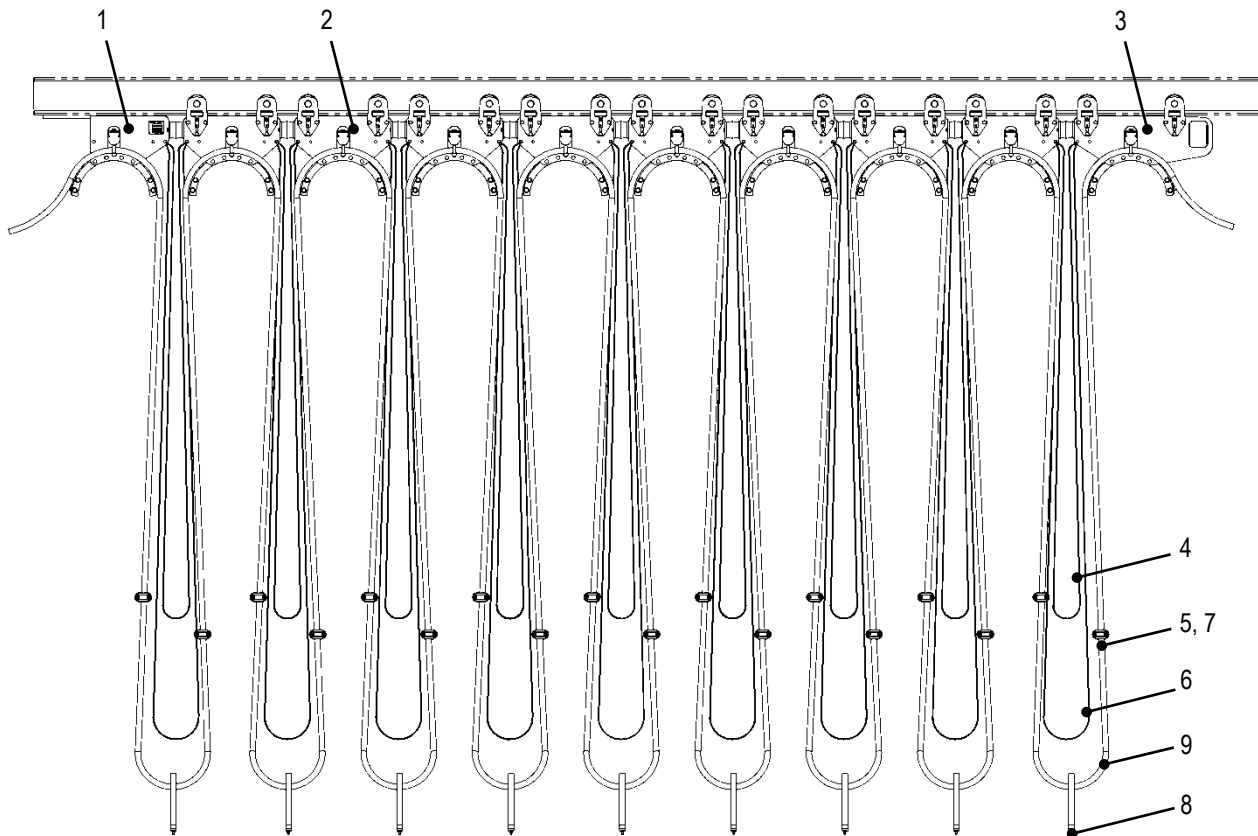

Fig. 10: Overview of the festoon system

- | | |
|--|-------------------------------------|
| 1) End clamp | 6) Damping device incl. shock cords |
| 2) Cable trolley | 7) Wind retaining device |
| 3) Towing trolley or towing clamp | 8) Cable organizer |
| 4) Towing rope | 9) Cable |
| 5) Round cable clamp or flat cable clamp | |

Festoon Systems for I-Beams Program 0350 / 0360 / 0364

4.2 Brief description

A festoon system consists of the end clamp, cable trolley, towing trolley or towing clamp, and cables. A towing arm (not included) couples the towing trolley or towing clamp to the mobile consumer. The towing trolley pulls and/or pushes the following cable trolley. Depending on the project, towing rope, shock cord, and round or flat cable clamps and cable organizers may also be used. The dimensions of the festoon system can be found in the project-specific dimension sheet.

4.3 Description of assemblies

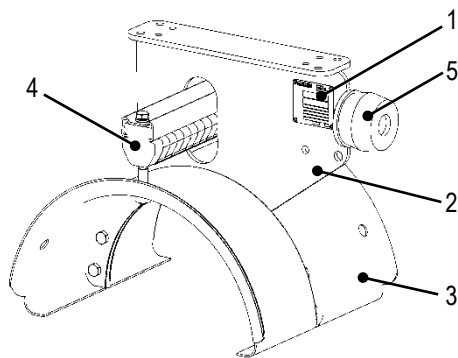

■ End clamp consisting of:

- 1) Type plate
- 2) Centre plate
- 3) Cable support
- 4) Clamping bar
- 5) Buffer

Fig. 11: End clamp

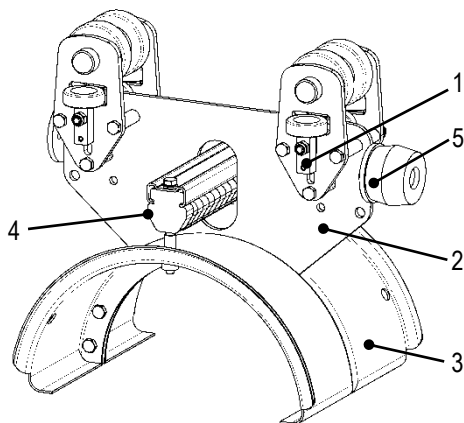

■ Cable trolley consisting of:

- 1) Running gear
- 2) Centre plate
- 3) Cable support
- 4) Clamping bar
- 5) Buffer

Fig. 12: Cable trolley

Mounting Instructions

Festoon Systems for I-Beams Program 0350 / 0360 / 0364

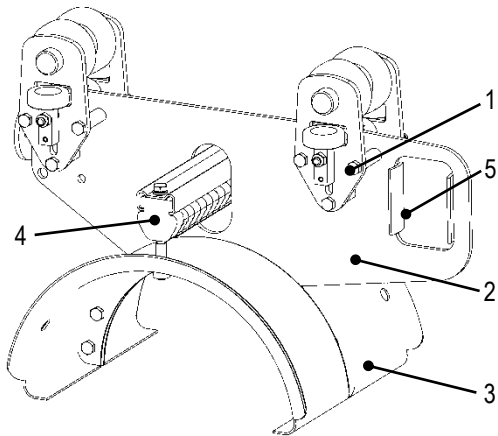

Fig. 13: Towing trolley

■ Towing trolley consisting of:

- 1) Running gear
- 2) Centre plate
- 3) Cable support
- 4) Clamping bar
- 5) Towing window

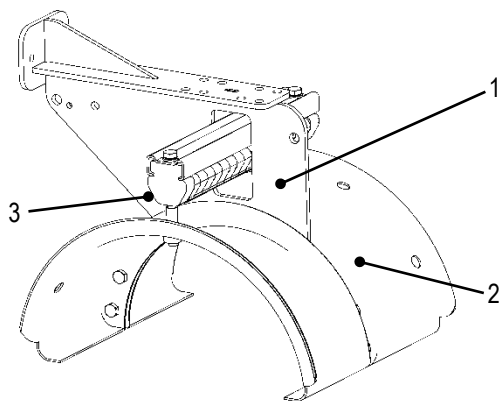

Fig. 14: Towing clamp

■ Towing clamp consisting of:

- 1) Centre plate
- 2) Cable support
- 3) Clamping bar

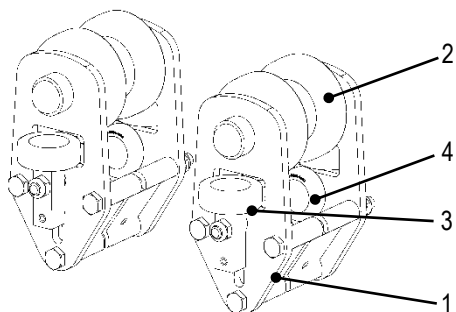

Fig. 15: Running gear

■ Running gear consisting of:

- 1) Side shield
- 2) Main roller (HTR)
- 3) Horizontal guide roller (HFR)
- 4) Anti-lift roller (GDR)

Mounting Instructions

Festoon Systems for I-Beams Program 0350 / 0360 / 0364

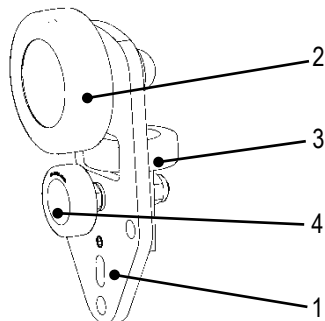

Fig. 16: Side shield

- Side shield consisting of:
 - 1) Side shield plate
 - 2) Main roller (HTR)
 - 3) Horizontal guide roller (HFR)
 - 4) Anti-lift roller (GDR)

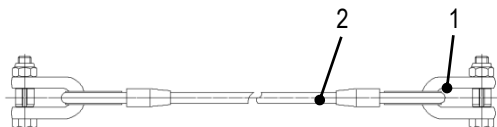

Fig. 17: Towing rope

- Towing rope consisting of:
 - 1) Shackle
 - 2) Steel cable

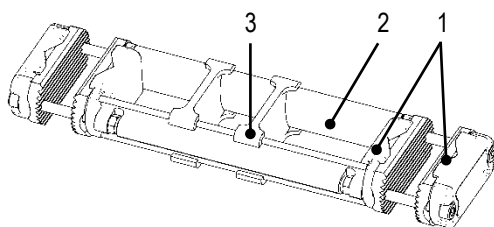

Fig. 18: Round cable clamp

- Round cable clamp consisting of:
 - 1) Clamping part
 - 2) Guiding profile
 - 3) Spacer

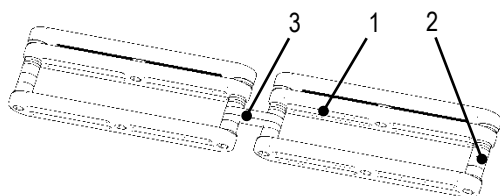
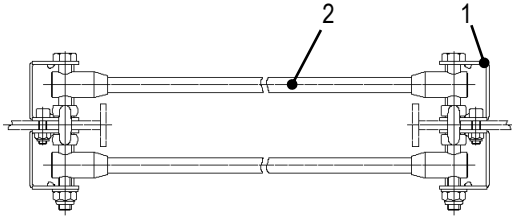

Fig. 19: Flat cable clamp

- Flat cable clamp consisting of:
 - 1) Clamping part
 - 2) Spacer
 - 3) Connecting part

Mounting Instructions

Festoon Systems for I-Beams Program 0350 / 0360 / 0364



- Damping device consisting of:
 - 1) Fastening bracket
 - 2) Shock cord

Fig. 20: Damping device

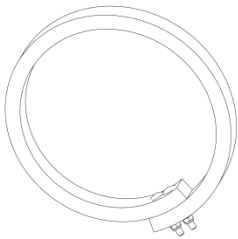

- Cable organizer

Fig. 21: Cable organizer

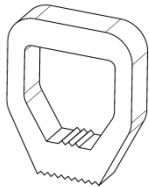

- Clamping piece

Fig. 22: Clamping piece

4.4 Working and danger areas

The following illustration shows the working area of the festoon system. There is a danger of injury from moving parts in this area.

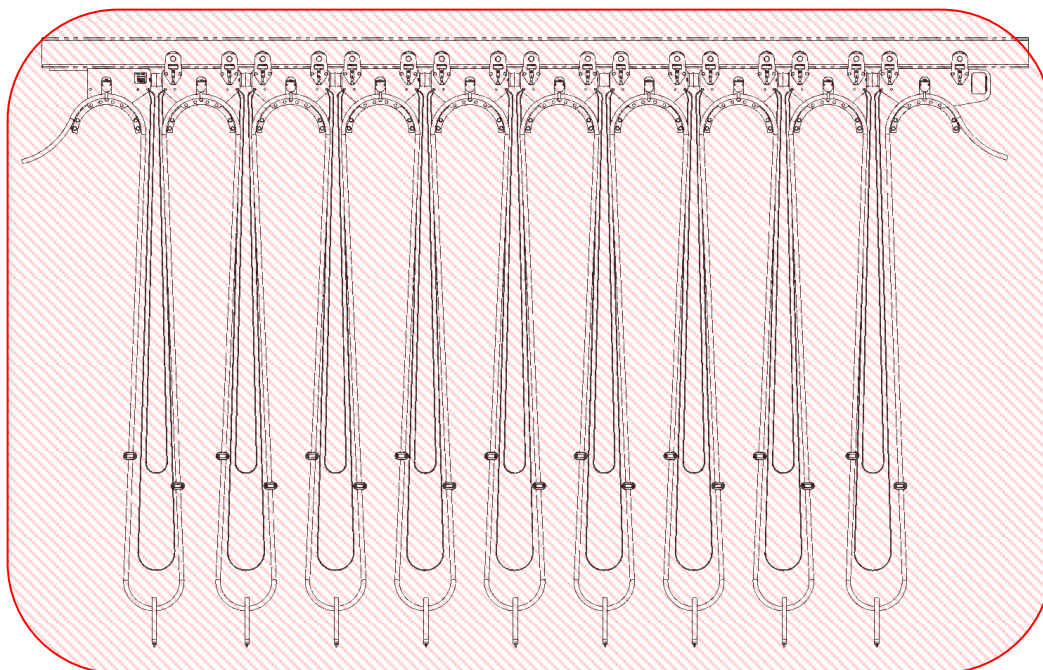

Fig. 23: Working and danger areas

Working and danger areas:

- In the area under the festoon system
- Between cable trolleys and track beams
- Between buffer and buffer plates
- Between load carriers and track beams
- In the vicinity of the cables



Danger of injury from moving components!

Contact with the festoon system during operation can lead to severe injuries and damage to the festoon system.

- During automatic operation, no-one may be located in or under the working area of the festoon system.
- In manual operation, the operator must ensure that no-one is in or under the working area of the festoon system.
- Block off the dangerous area under the system.

4.5 Operating modes

The festoon system can be operated in one of two modes:

- Automatic operation
- Manual operation

4.5.1 Automatic operation

The standard operating mode is automatic operation, in which the festoon system is operated via the consumer's controller. In this mode, no person may be in or under the working area of the festoon system. The customer must block off the working area.

4.5.2 Manual operation

Manual operation is used for commissioning, maintenance, and repair. It may be necessary to make adjustments directly at the festoon system and to monitor them.

5 Transport, packaging and storage

5.1 Transport

5.1.1 Safety instructions for transport



WARNING!

Danger of death due to hanging loads!

When lifting loads, there is a danger of death from falling parts or those swinging out of control.

- Never step under hanging loads.
- Block off the dangerous area under the system.
- Follow the specifications for the attachment points provided.
- Do not attach to projecting machine parts or to eyes on installed components. Be sure the connection elements are firmly seated.
- Use only authorized lifting accessories and connection elements with sufficient load capacity.
- Do not use torn or worn ropes or straps.
- Do not attach ropes or straps to sharp corners and edges, and do not knot or twist them.



CAUTION!

Possible damage from improper transport!

Improper transport can result in substantial property damage.

- Act with care when unloading packaged parts upon delivery as well as during internal transport, and observe the symbols and the hazard information on the packaging.
- Use only the attachment points provided.
- Wait to remove packaging material until just before installation.

5.1.2 Transport inspection

Check the delivery for completeness and transport damage immediately upon receipt.

If transport damage is externally visible, proceed as follows:

- Do not accept delivery, or accept it only with reservations.
- Note the scope of damage on the transport documents or on the transporter's delivery note.
- File a complaint.



NOTICE!

- Claim every defect as soon as it is detected. Damage compensation claims may only be made within the applicable claim periods.

5.2 Packaging

The individual packaged parts must be packed according to the transport conditions to be expected. Only environmentally friendly materials have been used for packaging.

The packaging must protect the individual components from transport damages, corrosion, and other damage until installation. Thus do not destroy the packaging and remove it only just before installation.

Handling packaging materials:

Dispose of packaging material according to valid legal regulations and local guidelines.



Environmental damage due to improper disposal!

Packaging material is a valuable resource and can be reused, processed or recycled in many cases.

- Dispose of packaging materials in an environmentally appropriate manner.
- Comply with locally applicable disposal guidelines; if necessary, engage a specialist with disposal.

5.3 Storage of packed parts

Store packed parts under the following conditions:

- Do not store outdoors.
- Store in a dry, dust-free place.
- Do not expose to aggressive media.
- Protect from direct sunlight.
- Avoid mechanical vibrations.
- Storage temperature: +5° to +40°C.
- Relative humidity: <90%, avoid condensation.
- When storing for more than 3 months, check the general condition of all parts and the packaging at regular intervals.



Under some circumstances, there may be instructions for storage on the packed parts which go beyond the requirements listed here. Follow them appropriately.

6 Installation and commissioning

6.1 Safety

Personnel:

- Installation and commissioning may only be carried out by specially trained technicians.

Wear the following protective gear during all work of installation and commissioning:

- Work safety clothing
- Hard hat
- Safety shoes
- Protective gloves



WARNING!

Danger of death due to hanging loads!

When lifting loads, there is a danger of death from falling parts or those swinging out of control.

- Never step under hanging loads.
- Block off the dangerous area under the system.
- Move loads only under supervision.
- Follow the specifications for the attachment points provided.
- Do not attach to projecting machine parts or to eyes on installed components. Be sure the connection elements are firmly seated.
- Use only authorized lifting accessories and connection elements with sufficient load capacity.
- Do not use torn or worn ropes or straps.
- Do not attach ropes or straps to sharp corners and edges, and do not knot or twist them.
- Set down the load when leaving the workplace.



WARNING!

Injury due to improper installation and commissioning!

Improper installation and commissioning can result in serious injury to person and property.

- Before starting work, ensure sufficient space for installation.
- Handle open, sharp-edges components carefully.
- Maintain order and cleanliness in the installation area! Loosely stacked or scattered components and tools are a source of accidents.
- Mount components properly. Comply with specified screw tightening torques.
- Secure components so that they cannot fall or fall over.

Festoon Systems for I-Beams Program 0350 / 0360 / 0364

6.2 Preparation

Tools needed:

- Drilling machine
- Metal drill
- Crescent wrench
- Corrosion protection
- Lubricant
- Gauges

6.3 Installation

Personnel:

- May only be carried out by trained technicians
- At least two people



CAUTION!

Danger of tripping on projecting parts!

When working on the festoon system, there is a risk of tripping.

- When walking in the work and danger area, be careful of projections and depressions in the floor.
No loose objects may be left on the floor.



WARNING!

Danger of crushing!

When moving the festoon system, there is a danger of crushing limbs between cable trolleys as well as between cable trolleys and the track beam.

- When the system is moving, do not enter the danger area of the festoon system.



WARNING!

Danger of crushing!

During installation of a festoon system, there is a danger of crushing limbs between the load carrier and the track beam.

- During installation, do not enter the danger area of the festoon system.

Festoon Systems for I-Beams

Program 0350 / 0360 / 0364



NOTICE!

The use of pre-assembled festoon systems (with pre-attached cables on the cable trolley) will save a significant amount of time and money.



CAUTION!

- Loads are to be carefully fastened onto suitable hoists or load-carrying devices that are technically intact and have sufficient load capacity.
- The use of a load track may be required, depending on the weight of the system.
- Before lifting a mounting structure, ensure that the cable trolley system is firmly installed on the mounting structure.
- Lift the mounting structure only in proper horizontal orientation.

6.3.1 Mounting a pre-assembled festoon system

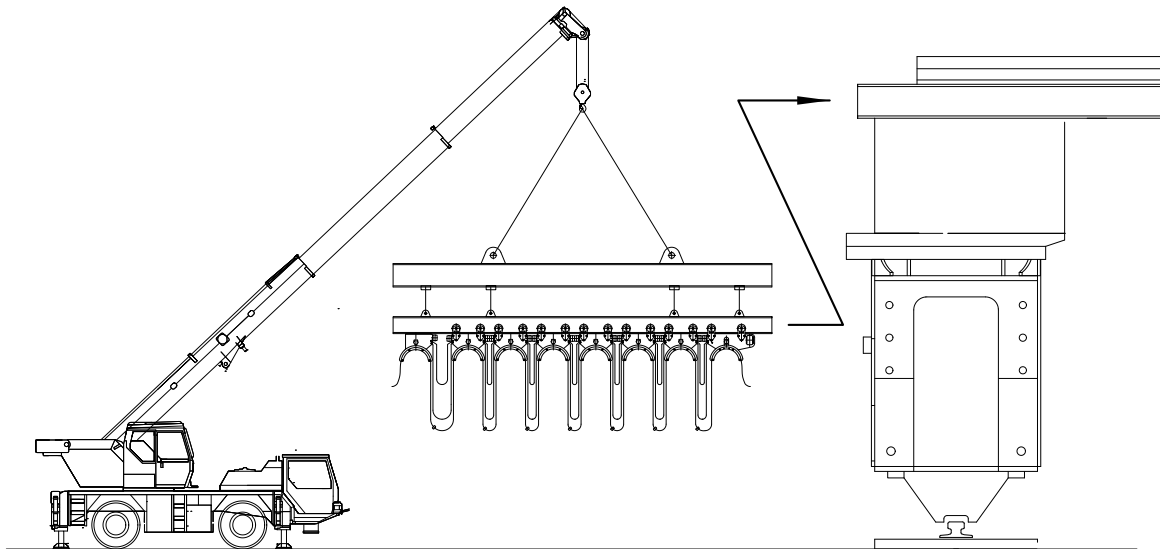

Fig. 24: Mounting a pre-assembled festoon system

The complete festoon system is delivered on a mounting structure and inserted into the front of the track beam.

Festoon Systems for I-Beams

Program 0350 / 0360 / 0364

6.3.2 Mounting a towing clamp



- Height differences between the cable trolley buffer and the tappet clamp buffer or tappet clamp deflector must be equalized using a filler plate.
- When installing the cable trolley with a buffer on one side, ensure that contact is always between buffers or between the buffer and the end stop, but that end stops do not collide.

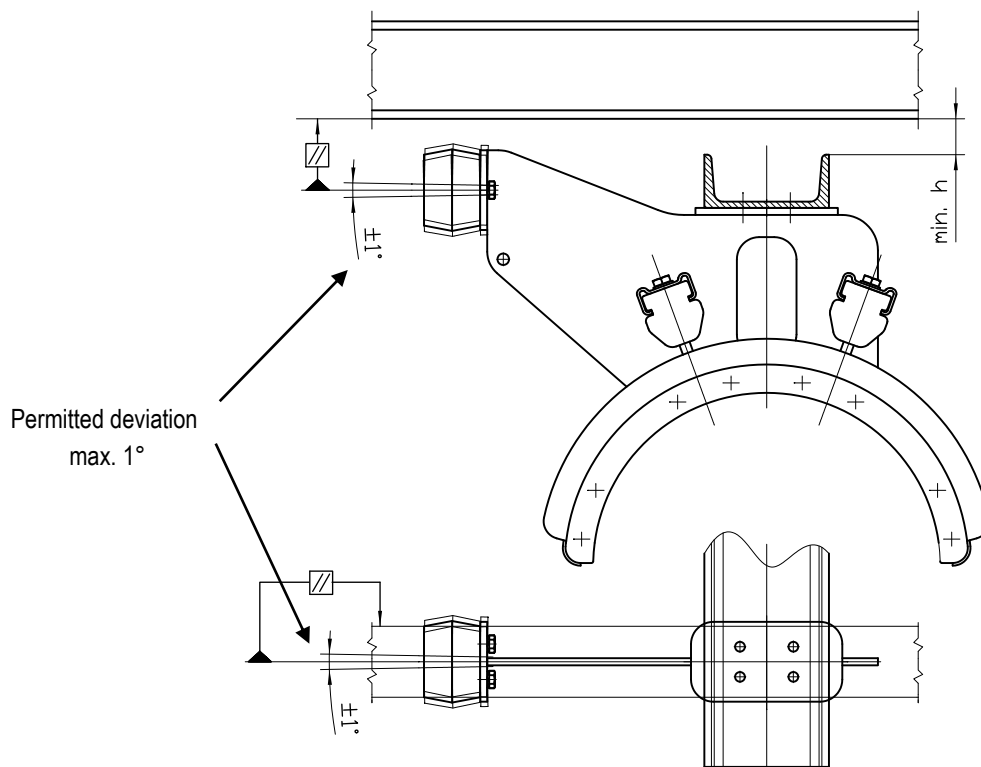

Fig. 25: Mounting a towing clamp

The towing clamp is fastened to the towing arm (provided by the customer) using a screw connection. The free space between the towing clamp/arm and the lower edge of the track beam must be at least 12 mm. The towing clamp should be installed and adjusted with a deviation of no more than 1° from the longitudinal and transverse axes of the traverse beam.

Festoon Systems for I-Beams

Program 0350 / 0360 / 0364

6.3.3 Mounting the towing trolley



Using a plastic block to hold the towing arm in the towing trolley window improves the longevity and reliability of the festoon system.

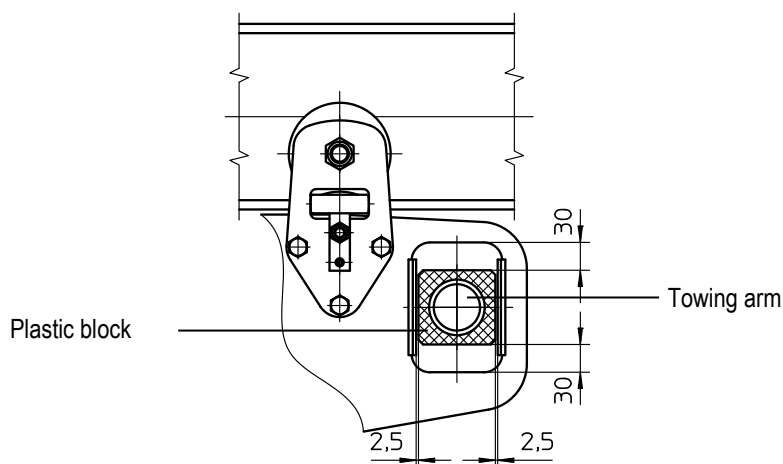

Fig. 26: Orientation of the towing arm

Push the towing trolley onto the front for the track beam. The towing arm must have enough play in the opening (towing window) in all directions. The towing arm must be aligned to the centre of the towing window.

6.3.4 Assembling the festoon



The trolley is adjusted ex works for the corresponding track beam. Usually subsequent adjustment is not necessary (for details see Section 6.3.12).

The trolleys are pushed into the front of the track beam.

6.3.5 Mounting the end clamp



- Height differences Δh greater than 5 mm between the trolley and the end clamp buffer must be compensated for by installing a filler plate.
- When installing the festoon with a buffer on one side, ensure that contact is always maintained between buffers or between the buffer and the end stop, but that end stops do not collide.

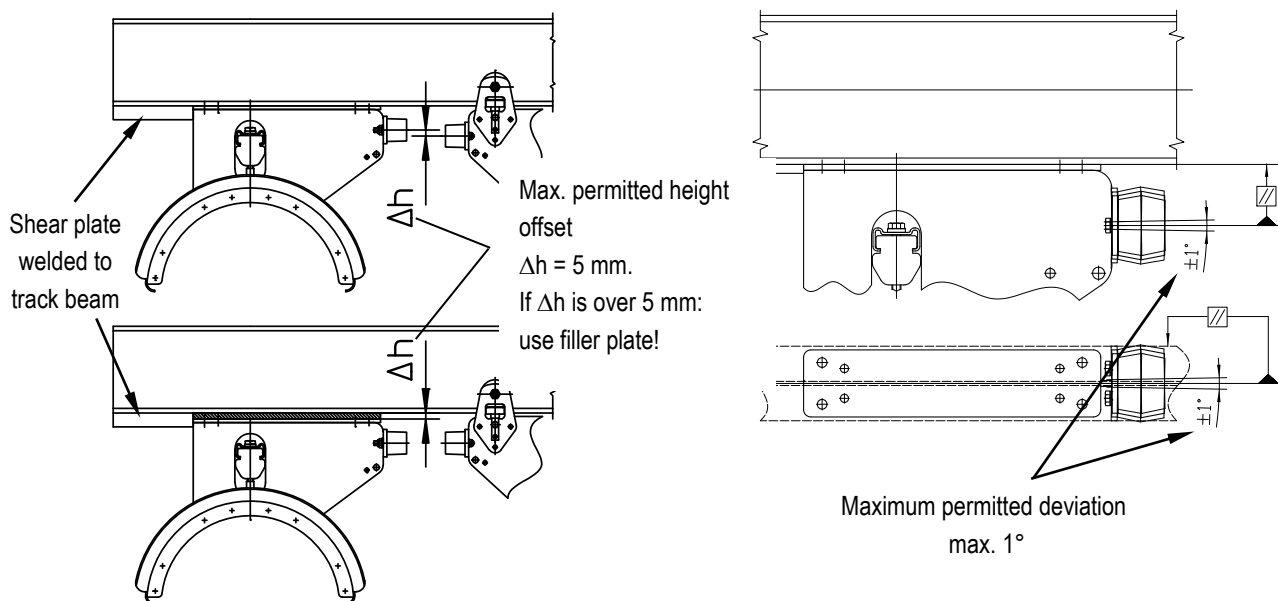

Fig. 27: Mounting the end clamp

The end clamp is fastened to the track beam (provided by the customer) using a screw connection. The end clamp should be installed and adjusted with a deviation of no more than 1° from the longitudinal and transverse axes of the track beam. A shear plate must then be welded on. Select the position of the end clamp so that when arranging the cables, the smallest bend radius of the cables can be maintained. The installation length is to be selected so that the cable is lying completely on the cable support and that the clamping is sufficient during operation.

Festoon Systems for I-Beams Program 0350 / 0360 / 0364



Only Program 0350 offers the option of an end clamp buffer with adjustable height. This is delivered at a halfway setting. By unscrewing the screws, the buffer can be adjusted to the height of the next cable trolley so that its buffer plate hits the end clamp buffer in the centre.

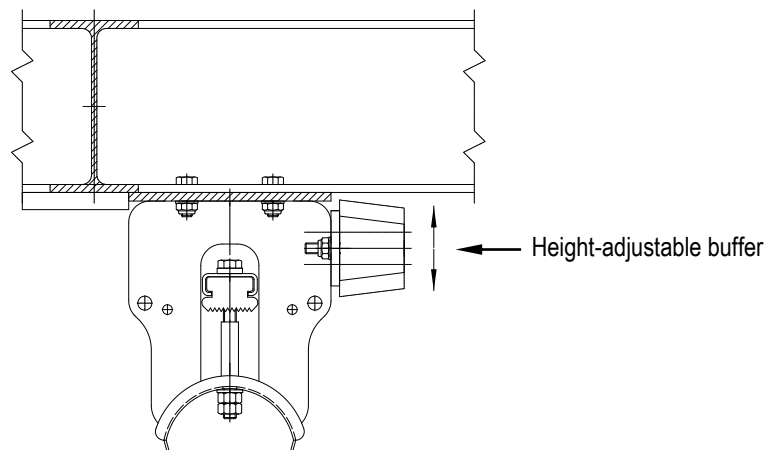

Fig. 28: Height-adjustable buffer, Series 350

6.3.6 Arrangement of round cables



WARNING!

Danger of burning!

Danger of burning when using insufficiently dimensioned cables!

→ Always comply with the necessary cross-section of cables.



WARNING!

Danger due to improper installation of cables!

Improper arrangement of cables in the cable packet and in loops can damage the cables and lead to death from electric shock.

→ The cables may only be connected by an electrician.

→ Inspect the cables regularly for wear and damage.

The projected cable setup for the festoon system is to be maintained. The following rules apply:

- Place the cable package towards the middle of the track beam so that the torque is in balance.
- Cables with large copper diameters are to be placed towards the center of the trolley and arranged symmetrically.
- When using cable trolleys with multiple cable support, the heaviest cables are to be placed on the uppermost support.
- When using cable trolleys with multiple cable support, the uppermost cables should be made slightly shorter than the cables below. Each layer of cables should be given somewhat less play than the cables below them.
- Each layer of cables should be given somewhat less play than the cables below them. When using round cable clamps, cables should be arranged on the outer surface of the supports that are suitable for anchoring the round cable clamps. Unshielded cables with a large copper diameter are preferred.

Festoon Systems for I-Beams

Program 0350 / 0360 / 0364

i
NOTICE!

Diameter differences:

The diameter of the round cables should be fairly uniform. This helps to ensure that they are tightly clamped on the cable supports.

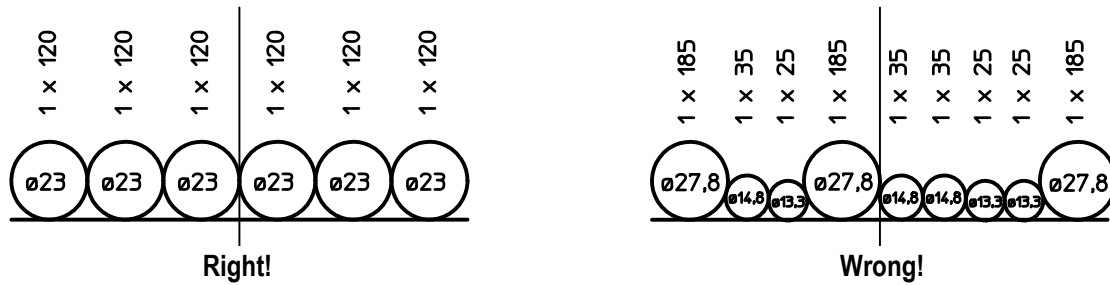

Fig. 29: Diameter differences

i
NOTICE!

Clamping pieces:

→ For differences in diameter of neighboring cables by more than 15 mm, clamping pieces should be used for tight clamping.

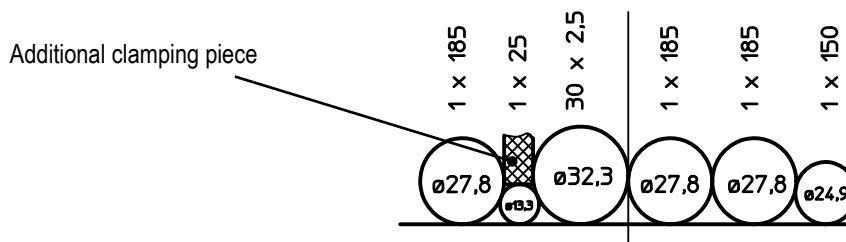

Fig. 30: Using clamping pieces

i
NOTICE!

Cable balance:

→ Pay attention to the torque balance when positioning the cables. The thicker, heavier cables should be placed in the middle.

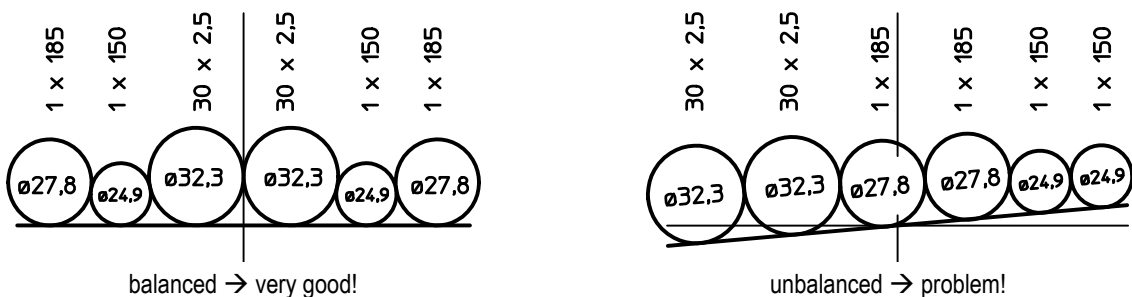

Fig. 31: Cable balance

Festoon Systems for I-Beams Program 0350 / 0360 / 0364

6.3.7 Arrangement of flat cables



Danger of burning!

Danger of burning when using insufficiently dimensioned cables!
→ Always comply with the necessary cross-section of cables.



Danger due to improper installation of cables!

Improper arrangement of cables in the cable packet and in loops can damage the cables and lead to death by electric shock.
→ The cables may only be connected by an electrician.
→ Inspect the cables regularly for wear and damage.

The projected cable setup for the festoon system is to be maintained. The following rules apply:

- Place the cable package towards the middle of the track beam so that the torque is in balance.
- When using layered flat cables, give each layer of cables slightly less slack than the layer below.
- When using cable trolleys with multiple cable support, the uppermost cables should be made slightly shorter than the cables below. Each layer of cables should be given somewhat less play than the cables below them.
- Cables with large copper diameters are to be placed symmetrically to the center of the trolley and at the top of the cable package.
- When using flat cable clamps, only the uppermost cables are clamped. The other cables must be freely movable in the flat cable clamp window.

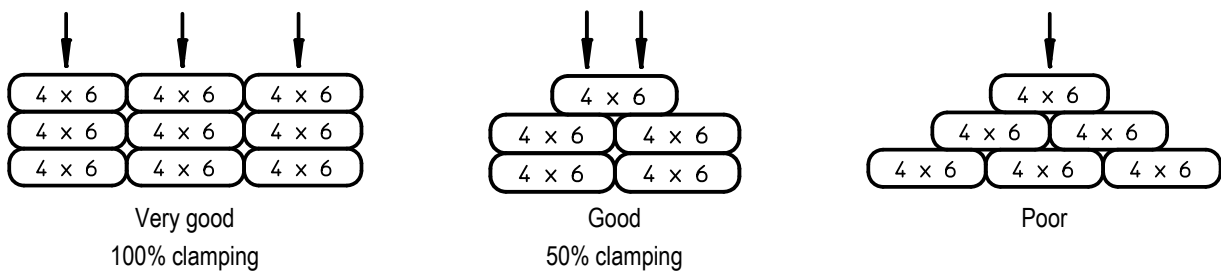
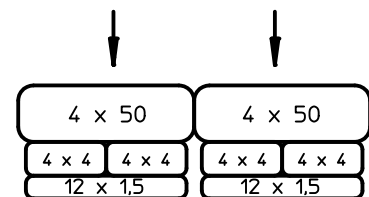

Fig. 32: Arrangement of flat cables

Thicker cables (such as 4x50) are to be placed at the top of the cable package. This allows for good heat dissipation and tight clamping of smaller cables. Traction forces that occur during movement can be taken up by these cables.



Festoon Systems for I-Beams

Program 0350 / 0360 / 0364

6.3.8 Mounting round cable clamps



CAUTION!

- Improper positioning of the round cable clamps can lead to damage of the cables and festoon system.
- Improper mounting and arrangement of cables in the round cable clamp can damage the cables and the cable trolley system.

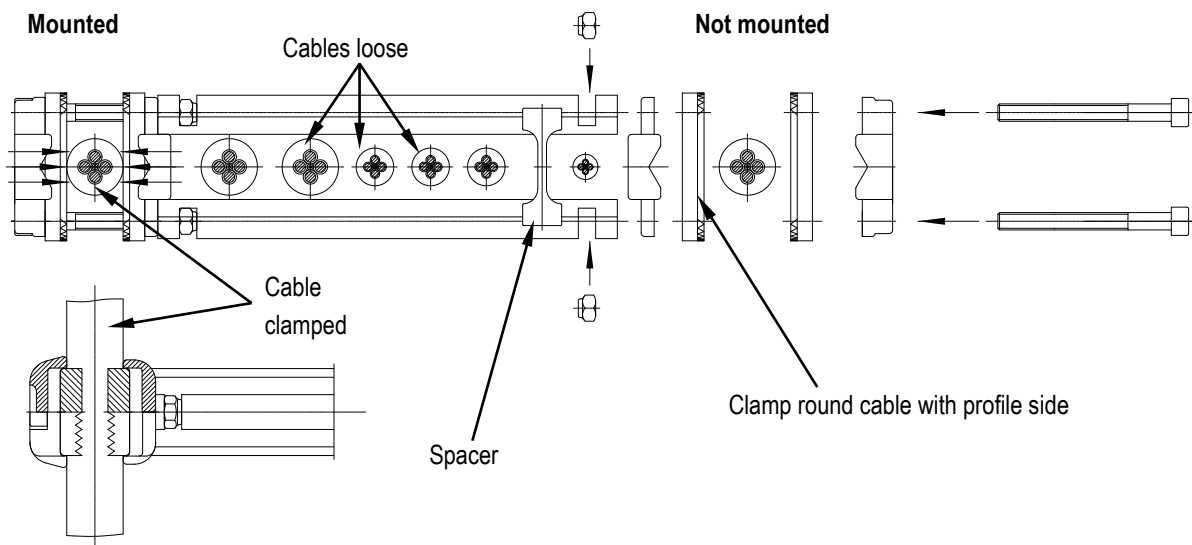

Fig. 33: Mounting round cable clamps



NOTICE!

It is recommended that the round cable clamps be preassembled as shown in this diagram in order to maintain two identical halves.

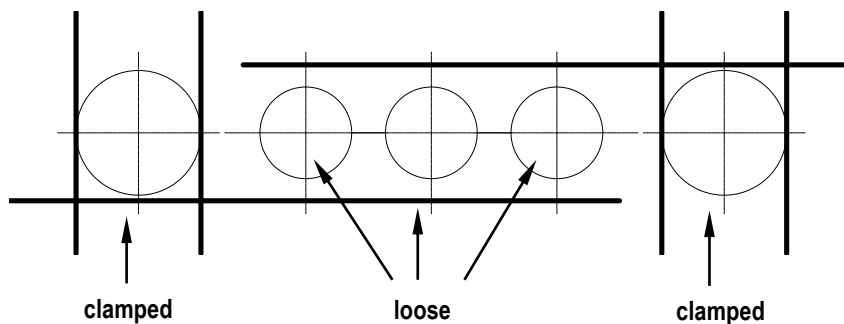

Fig. 34: Schematic diagram of preparation for installation of round cable clamps

The outer left and right cables are firmly clamped between the rubber profiles.

Mounting Instructions

Festoon Systems for I-Beams

Program 0350 / 0360 / 0364

Ensure that the inner cables can move freely in the round cable clamp window.

If spacers need to be used (in order to prevent turning and superimposition of cables), insert them before closing the cable clamp.

The use of spacers depends on the diameter of the cables. The cable clamp screws must be lubricated. Screws must be tightened crosswise.



Spacers:

Improper positioning or removal of spacers in round cable clamps can cause damage to the cables or the cable trolley system.

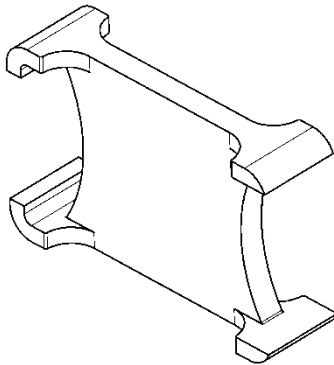

Fig. 35: Spacer

Festoon Systems for I-Beams Program 0350 / 0360 / 0364

6.3.9 Mounting flat cable clamps



→ Clamp the uppermost cables in the flat cable clamp. The other cables must be freely movable in the flat cable clamp window.



→ Improper positioning of the flat cable clamps can lead to damage of the cables and festoon system.
→ Improper mounting and arrangement of cables in the flat cable clamp can damage the cables and the festoon system.

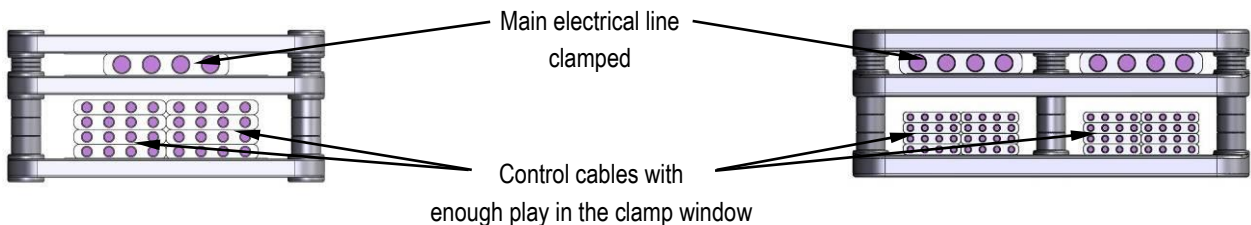

Fig. 36: Installing flat cable clamps

The arrangement of the spacers allows for the height of the flat cable clamp to be adapted to the cable package. The window for the control cable is to be adjusted so that the cables of the block have enough play (>5 mm) in the window. The cable clamp screws must be lubricated.

6.3.10 Mounting the towing rope



→ It is important to ensure that the shackles and thimbles can move freely once assembled.

The towing rope is installed between two cable trolleys, end clamps, and cable trolley, or between a towing trolley/clamp and a cable trolley.

- Ensure that the shackles can be easily moved after tightening the retaining nut. The shackles must be serviced at regular intervals (see Chapter "Maintenance").
- If towing ropes are used with bushings, the bushings must be pressed or hammered into the drill hole in the centre plate.

Mounting Instructions

Festoon Systems for I-Beams Program 0350 / 0360 / 0364

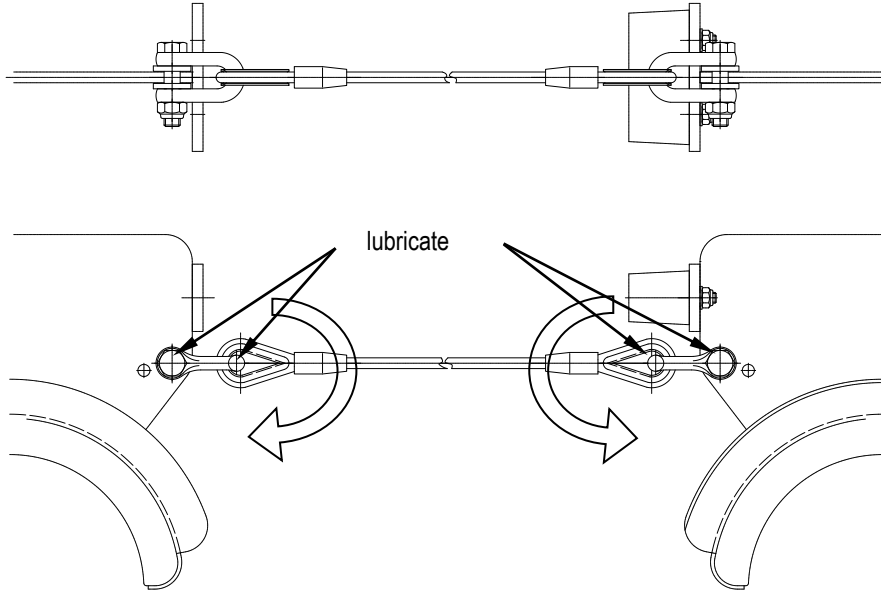

Fig. 37: Towing rope without bushing

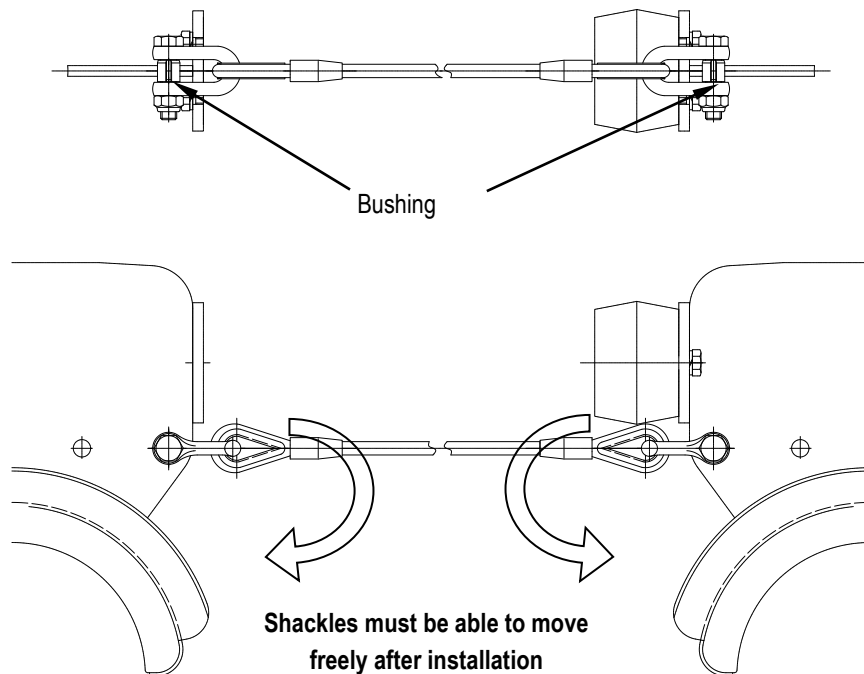

Fig. 38: Towing rope with bushing

Festoon Systems for I-Beams Program 0350 / 0360 / 0364

6.3.11 Damping device



→ Be sure that the fastening eyes can still move slightly after tightening of the lock nut, or in the case of slack shock cords, can tip over alone.



CAUTION!

Bodily harm

→ Before approaching systems with damping devices, they must first be released.

The damping device is installed between two cable trolleys, end clamps, and cable trolley, or between a towing trolley/clamp and a cable trolley. Be sure that the fastening eyes can still move slightly after tightening of the lock nut, or in the case of slack shock cords, can tip over alone.

If required by the project, damping devices with 2, 4, or 6 shock cords can be used.

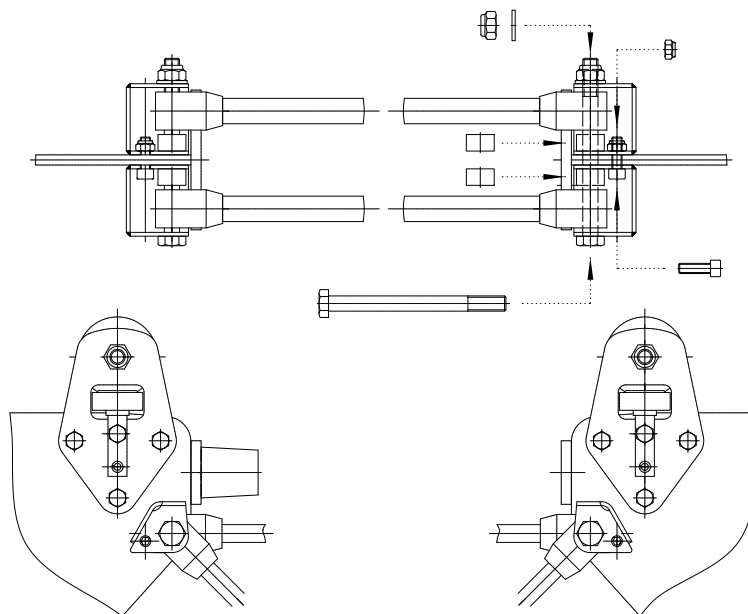

Fig. 39: Damping device with 2 shock cords, for main rollers of diameter 50 mm and 63 mm

Mounting Instructions

Festoon Systems for I-Beams Program 0350 / 0360 / 0364

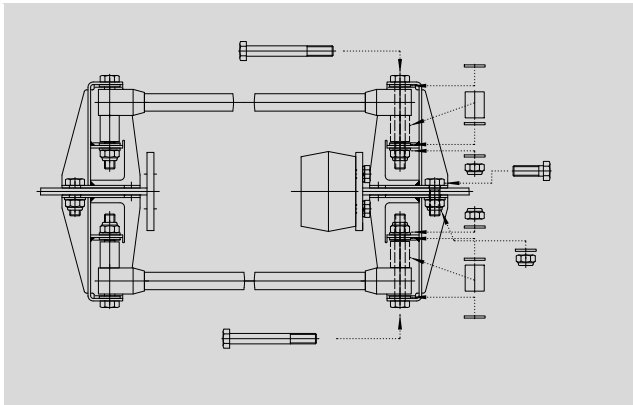

Fig. 40:
Damping device with 2 shock cords,
for main roller diameters of 80, 100, 112, 125, and 160 mm

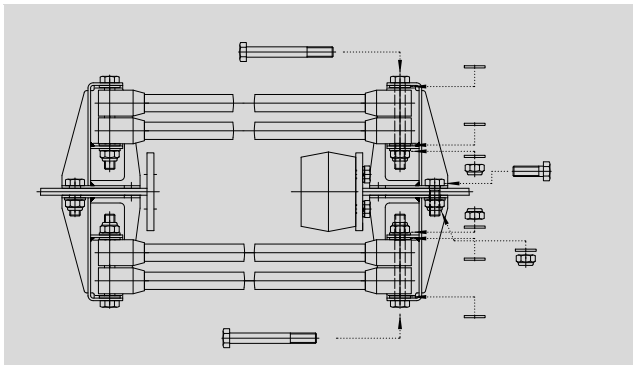

Fig. 41:
Damping device with 4 shock cords,
for main roller diameters of 80, 100, 112, 125, and 160 mm

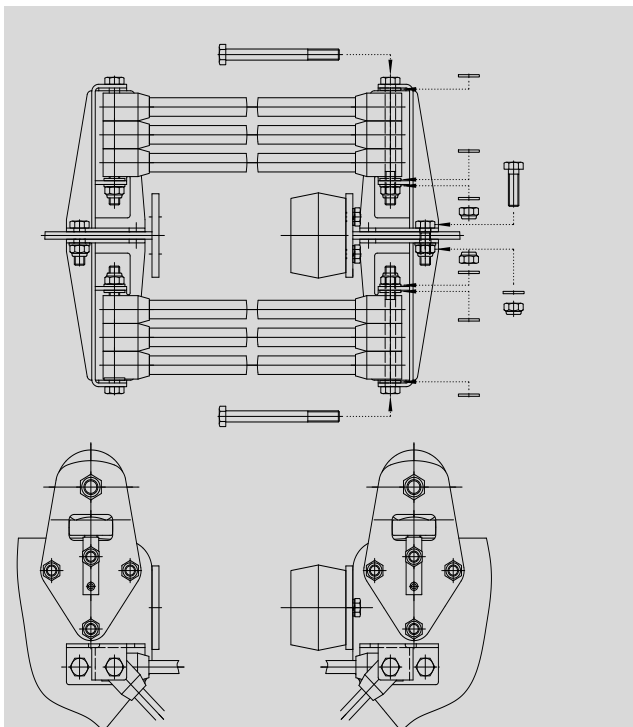

Fig. 42:
Damping device with 6 shock cords,
for main roller diameters of 80, 100, 112, 125, and 160 mm

Festoon Systems for I-Beams

Program 0350 / 0360 / 0364

6.3.12 Adjusting the running gear

The guide rollers of the trolleys are delivered set to the maximum width tolerance indicated for the track beams at the time of ordering.



- Trolleys with horizontal guide rollers must be checked for wear in accordance with maintenance instructions.
- Should proper guiding of the cable trolley no longer be possible due to wear or deviation of the guide rollers, the guide rollers must be replaced.

Before commissioning the system, the trolleys must be inspected and the horizontal guide rollers must be adjusted to the actual width of the track beam. The distance between the horizontal guide roller and the beam should be **at most 1 mm**. For adjustment, dismount the horizontal guide rollers and remove the spacers installed at the factory. This can be done on the side plates on one side or on both sides, depending on the actual size of the beam. Then remount the horizontal guide rollers. Tighten all nuts firmly.

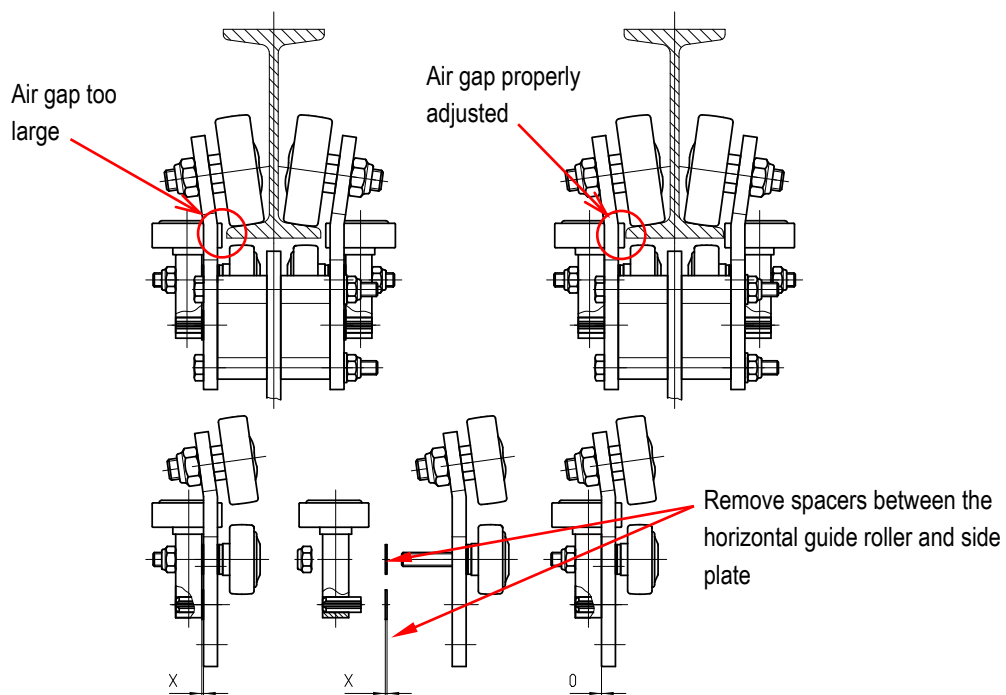

Fig. 43: Adjusting the running gear of a trolley

6.4 Testing and commissioning



WARNING!

Danger of injury due to improper commissioning!

Improperly performed commissioning can lead to dangerous situations for personnel.

- Before commissioning, carry out the tests in the test list of the manufacturer.
- Never start the festoon system without testing according to the manufacturer's test list.
- Before commissioning, perform a visual check and carry out the prescribed tests.
- Any procedures that could threaten safety are to be avoided.
- Notify the responsible person immediately of any damage to the festoon system.
- The festoon system should only be operated with functional protective gear and safety devices.
- It is forbidden to enter the operating area of the festoon system.



CAUTION!

Danger of tripping on projecting parts!

When working on the festoon system, there is a risk of tripping.

- When walking in the work and danger area, be careful of projections and depressions in the floor.
No loose objects may be left on the floor.



WARNING!

Danger of crushing!

When moving the festoon system, there is a danger of crushing limbs between the buffer and buffer plate, as well as between the running gear and the track beam.

- When the system is moving, do not enter the danger area of the festoon system.



CAUTION!

Trap!

When the festoon system is moving, there is a danger of being trapped within it.

- When the system is moving, do not enter the danger area of the festoon system.

The festoon system is commissioned together with the system operator and is documented. All necessary personnel for commissioning including operators, electricians and installation technicians are to be provided by the system operator for the course of commissioning. Free access to the system must be provided. After commissioning is complete, Conductix-Wampfler will receive an authorized final acceptance protocol from the operator, in which it is logged that the system corresponds to the requirements.

Mounting Instructions
Festoon Systems for I-Beams
 Program 0350 / 0360 / 0364
Commissioning Checklist

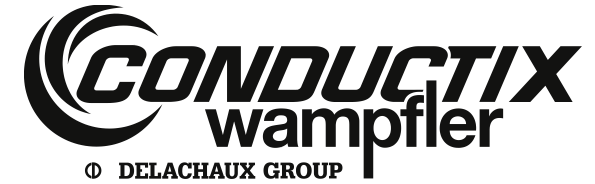

6.4.1 Commissioning checklist



This checklist should be used as a guideline to ensure the safety operation of the festoon system. The operating instructions are intended for qualified specialists who install the festoon systems, operate them and who are familiar with the requirements regarding work safety and accident prevention.
If Conductix-Wampfler performed the commissioning, fill in the final acceptance protocol on the last page.

Customer:		Cust. No.:	
		Order No.:	
Customer:		Order No.:	
Commissioning location:		Postal code:	
Address:		Country:	
Name of system:	SAMPLE		
Start of commissioning:		Commissioner	
Ending of commissioning:		Name:	
		Date:	
		Signature:	

Mounting Instructions
Festoon Systems for I-Beams
 Program 0350 / 0360 / 0364
Commissioning Checklist

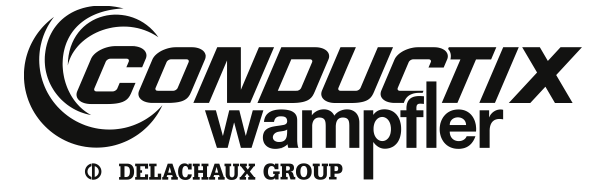

Inspections on deactivated system			OK	Not OK
A01	The travel length of the trolley corresponds to the project-specific technical documentation.		<input type="checkbox"/>	<input type="checkbox"/>
A02	The storage length of the festoon system corresponds to the project-specific technical documentation.		<input type="checkbox"/>	<input type="checkbox"/>
A03	There are <u>no</u> height differences - all buffers meet centrally.		<input type="checkbox"/>	<input type="checkbox"/>
A04	The end clamp is mounted on the track beam in proper alignment: <small>Vertical and horizontal deviation target $\pm 1^\circ$</small>	Actual _____	<input type="checkbox"/>	<input type="checkbox"/>
A05	The end clamp is equipped with a shear plate that has been subsequently welded on the track beam.		<input type="checkbox"/>	<input type="checkbox"/>
A06	The towing clamp is mounted at the right height and centrally meets the buffer of the 1st cable trolley.		<input type="checkbox"/>	<input type="checkbox"/>
A07	The towing clamp is mounted on the track beam in proper alignment: <small>Vertical and horizontal deviation target $\pm 1^\circ$</small>	Actual _____	<input type="checkbox"/>	<input type="checkbox"/>
A08	All screws have a sufficient length and are secured. The projecting ends of the screws are visible (at least 2 thread projection).		<input type="checkbox"/>	<input type="checkbox"/>



The pages which are marked SAMPLE are only included to show the design of the commissioning checklist.
 You'll find the actual commissioning checklist in the **Document No. TDB0300-0003!**

7 Operation

7.1 Safety



WARNING!

Danger of death due to hanging loads!

When lifting loads, there is a danger of death from falling parts or those swinging out of control.

- Never step under hanging loads.
- Block off the dangerous area under the system.
- Move loads only under supervision.
- Follow the specifications for the attachment points provided.
- Do not attach to projecting machine parts or to eyes on installed components. Be sure the connection elements are firmly seated.
- Use only authorized lifting accessories and connection elements with sufficient load capacity.
- Do not use torn or worn ropes or straps.
- Do not attach ropes or straps to sharp corners and edges, and do not knot or twist them.
- Set down the load when leaving the workplace.



WARNING!

Danger of injury due to improper operation!

Improper operation can result in serious injury to person and property.

- Carry out all operating steps according to the specifications of these operating instructions.
- Before starting work, be sure that all covers and safety systems are installed and working properly.
- Never disable the safety systems during operation.
- Maintain order and cleanliness in the working area! Loosely stacked or scattered components and tools are a source of accidents.



WARNING!

Danger for unauthorized personnel!

Unauthorized personnel who do not meet the requirements described here do not understand the danger in the work area.

- Keep unauthorized personnel away from the work area.
- In case of doubt, address personnel and warn them away from the work area.
- Cease working as long as unauthorized personnel are present in the work area.



CAUTION!

Danger of tripping on projecting parts!

When working on the festoon system, there is a risk of tripping.

- When walking in the work and danger area, be careful of projections and depressions in the floor. No loose objects may be left on the floor.

Festoon Systems for I-Beams Program 0350 / 0360 / 0364



WARNING!

Danger of crushing!

When moving the festoon system, there is a danger of crushing limbs between the buffer and buffer plate, as well as between the running gear and the track beam.

→ When the system is moving, do not enter the traveling area of the festoon system.



WARNING!

Danger of crushing!

During assembly of the festoon system, there is a danger of crushing limbs between load carrier and the track beam.

→ During assembly, do not enter the travel area of the festoon system.



CAUTION!

Trap!

When the festoon system is moving, there is a danger of being trapped within it.

→ When the system is moving, do not enter the traveling area of the festoon system.

Personnel:

- The system may only be operated by trained personnel!

7.2 Function

A towing arm couples the towing trolley to the mobile consumer. The towing trolley pulls and/or pushes the following cable trolley. The cables are held on the supports with clamping bars. For improved shock absorption when trolleys meet, buffers are placed on the festoon system. Depending on the project, towing ropes, shock cord, and round or flat cable clamps and cable organizers may also be used.

The dimensions of the festoon system can be found in the project-specific dimension sheet.

The system is to be checked for changes in running noise and irregularities during operation.

If irregularities are determined during operation, then the system is to be stopped immediately. The cause of the fault is to be determined using the fault table (see Section 9).

The fault table includes the causes for the disturbance as well as the recommendations for their remedy. If the cause cannot be determined or if there is no way to repair the system with the company's resources, then we recommend that you request a service technician from our customer service.

8 Maintenance and service

8.1 Safety



WARNING!

Danger of injury due to improperly executed maintenance tasks!

Improper maintenance can result in serious injury to person and property.

- Before starting work, ensure sufficient space for assembly.
- Maintain order and cleanliness in the assembly area! Loosely stacked or scattered components and tools are a source of accidents.
- If components have been removed, be careful to reinstall them properly, replace all fastening elements, and comply with screw tightening torques.



WARNING!

Danger of injury from moving components!

Incautious handling of the festoon system can lead to severe injury or damage to the festoon system.

- Be sure that the festoon system does not start by itself.
- While it is moving, do not reach into moving parts, particularly the interface between the buffer and buffer plate.
- Block off the dangerous area under the system.



CAUTION!

Danger of tripping on projecting parts!

When working on the festoon system, there is a risk of tripping.

- When walking in the work and danger area, be careful of projections and depressions in the floor. No loose objects may be left on the floor.



WARNING!

Danger of crushing!

When moving the festoon system, there is a danger of crushing limbs between the buffer and buffer plate, as well as between the running gear and the track beam.

- When the system is moving, do not enter the danger area of the festoon system.



WARNING!

Danger of crushing!

During assembly of the festoon system, there is a danger of crushing limbs between load carrier and the track beam.

- During assembly, do not enter the danger area of the festoon system.



CAUTION!

Trap!

When the festoon system is moving, there is a danger of being trapped within it.

- When the system is moving, do not enter the danger area of the festoon system.

Festoon Systems for I-Beams Program 0350 / 0360 / 0364

8.2 Maintenance / inspection plan

The next sections describe the maintenance tasks required for optimum, trouble-free operation. If regular inspections reveal increased wear, the corresponding maintenance intervals should be shortened in accordance with the actual signs of wear.

Where there are 2 **maintenance intervals** stated for one maintenance task, the maintenance interval which is reached first is valid.

Example: Maintenance interval "After 300 hours of operation or every month".

If 300 hours of operation are reached before one month has elapsed, the maintenance task has to be performed after 300 hours. If the installation has been operated less than 300 hours in one month, the maintenance task has to be performed when one month has gone by since the last servicing.

Contact the manufacturer with any questions about maintenance tasks or intervals.

In order to retain the warranty rights and to avoid damage, the system operator is responsible for performing the following maintenance tasks. Inspection, service and repair are to be performed and documented by trained and qualified specialists.



NOTICE!

The intervals indicated for maintenance are dependent for the most part on operational conditions of the festoon system. Therefore only mean values can be indicated here.

The following tasks fall under the category "Maintenance":

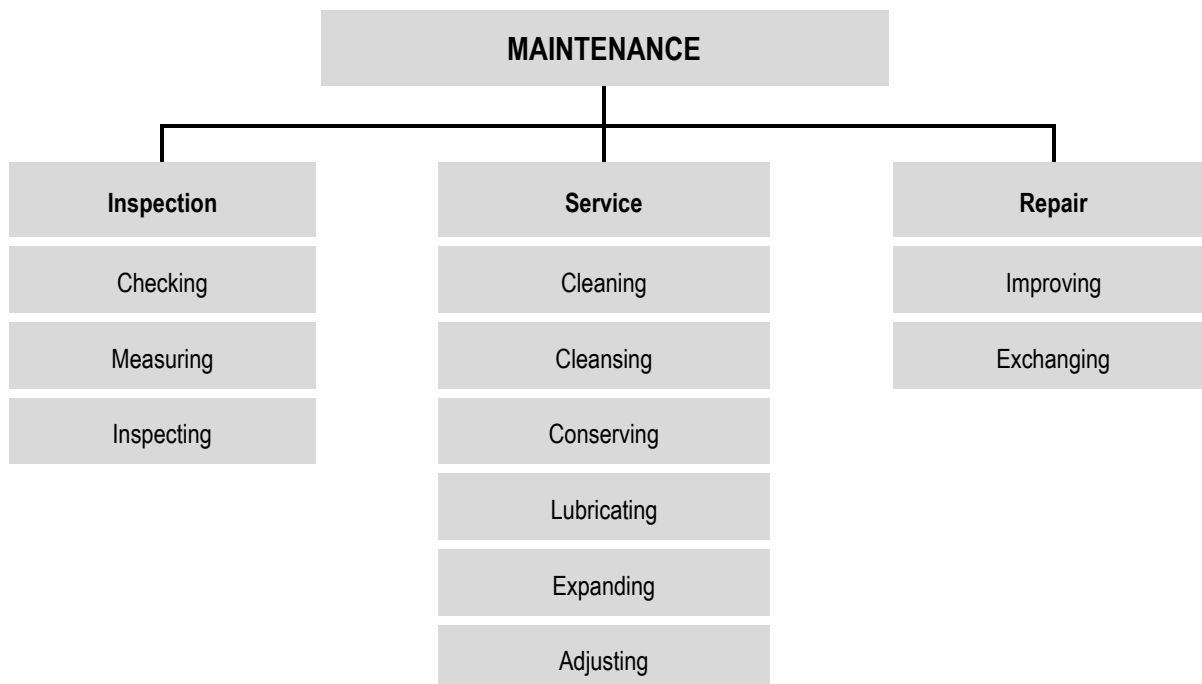

Festoon Systems for I-Beams Program 0350 / 0360 / 0364

8.2.1 Inspection on deactivated system



CAUTION!

- Protect the festoon system from inadvertent activation.
- Safety devices that were removed during inspection of the resting system must be immediately remounted and checked after completion of work.
- Check measuring tools used after clean up/ collection and inventory.
- Before approaching systems with damping devices, they must first be released.

Inspection measures

Interval	Component	Task Description	Description
After 300 hours of operation or every month See Chapter 8.2	Rollers	Visual inspection	- for proper condition
	Buffers		- for proper function
	Center plate		- for proper mobility
	Cable supports		- for firm seating
	Fasteners		- for deformations
	Cables		- for wear
	Cable clamps		- for damages
	Fixed installation length		- for dirt
	Installation connections		- for corrosion
	Towing ropes		
	Damping device		
	Towing devices		
	End stops		
	Track beam		

8.2.2 Inspection of towing ropes and criteria for replacement



CAUTION!

→ In case of defect, towing ropes must be removed from use immediately. They must be replaced.

A towing rope must be replaced if one or more of the following criteria are fulfilled:

1. Wire breakage
2. Structural changes
3. Corrosion
4. Abrasion

The following steel cable deformations are leading to a necessary replacement:

- Corkscrew-like deformation: Replace the cable if it has corkscrew deformations with waves that measure more than a third of the cable diameter.
- Fraying: Replace the cable if it starts to fray.
- Loop formation: Replace the cable if loop formation has led to significant changes in the cable structure.
- Loosening: Replace if wires are loosened due to rust or abrasion.
- Node formation: Replace if nodes- points where the cable is widened- form in the steel cable.
- Constrictions: Replace in case of severe constrictions in the cable.
- Curling: Replace the towing rope if permanent deformations are present such as those caused by being pulled over a corner.
- Kinks: Replace if kinks form after tension is applied to cable loops.
- Bends: Replace the towing rope if it has been bent by an external force.

Mounting Instructions

Festoon Systems for I-Beams Program 0350 / 0360 / 0364

8.2.3 Inspection on moving system



- Any procedures that could threaten safety are to be avoided.
- The system should only be commissioned with functional protective gear and safety devices.
- It is forbidden to enter the operating area of the festoon system.

Inspection measures

Interval	Component	Task Description	Description
After 300 hours of operation or every month See Chapter 8.2	Rollers	Function Test	For easy and unobstructed running of the main rollers, horizontal guide rollers and anti-lift rollers on the track beam. Visible wear, damage.
	Cable trolley		For proper entry and exit of the cable trolleys in the storage area
	Towing device		For reliable operation of the towing device based on the required horizontal and vertical balancing movements.
	Buffer unit towing or end clamp		For functionality of the damping device, especially when the system is in the storage.
	Towing ropes Damping devices		For functionality of the towing ropes and damping devices, especially when the system is completely extended.
	Track beam and system		For the track beam and the entire system, for dirt and corrosion that influence functionality.

Should problems be identified during inspection, service work is urgent.

8.2.4 Logging

The results of inspections as well as the remedies performed are to be documented in written reports. Conductix-Wampfler must be informed immediately of defects and malfunctions during the test phase and the warranty period.

8.2.5 Maintenance of the festoon system



CAUTION!

- Turn off power supply and ensure that no inadvertent activation is possible.
- When installation tasks are carried out above eye level, use proper climbing aids and working platforms.
- Do not use machine components as climbing aids.
- Ensure that exhaust, collection and disposal of process materials is done in a safe and environmentally-friendly manner.
- Safety devices that were removed for installation, service or repair must be immediately remounted and inspected after work is completed.
- Observe the inspection and maintenance intervals described in the maintenance instructions.
- Ensure that sufficient space for maintenance work (danger area) is available.
- Ensure that the festoon system is not inadvertently activated during maintenance work.
- Ensure that detached parts do not fall.
- Screw joints that are disconnected during maintenance work are to be reattached (with suitable torque) and secured as instructed.
- Fasteners and seals that cannot be reused are to be replaced (such as self-locking nuts, disks, splints, O-rings, glued or microencapsulated screws).
- Lubrication points that are cleaned or wiped during maintenance and repair work must be re-lubricated as instructed.
- After finishing work, collect all tools and materials and check that all are present.
- Disassembled parts and components that were exchanged are to be collected, stored in a safe place, recycled or sent back.
- Before approaching systems with damping devices, these must be released.

Mounting Instructions



Festoon Systems for I-Beams Program 0350 / 0360 / 0364

Service measures

Interval	Component	Task Description	Description
After 300 hours of operation or every month See Chapter 8.2	Roller mounting	Service performed	Tighten all fasteners.
	Cable mounting		Tighten all fasteners on clamping bars and cable clamps.
	Towing device		Exchange worn parts if necessary.
	Damping device		Exchange shock cords if necessary.
Every 3 months	Towing rope		Tighten mounting screws. Lubricate the contact surfaces of the shackles.
	Buffers towing or end clamp		Tighten all fasteners. Exchange worn parts if necessary.
Annually (depends on external influences)	Surface/ corrosion protection Corrosion coating	repair / replace	Refinish hot-dip galvanized surfaces with zinc coating. Refinish lacquered surfaces.

Festoon Systems for I-Beams Program 0350 / 0360 / 0364

8.2.6 Wearing parts

Wearing parts are excluded from the warranty. This includes:

- All trolley rollers including main rollers, horizontal guide rollers, anti-lift rollers.
- Cable (expander and/or shock cord) on the damping devices.
- Special damping systems in the towing arm window.
- Rubber or cellular buffers.
- Other definitions require written documentation.

8.2.7 Wear limits

Component	Wear limit has been reached if
Rollers	<ul style="list-style-type: none"> - the diameter of the roller has been reduced from the nominal diameter by 2 mm - sharp impressions can be seen - cracks, broken-off pieces, or embrittlements have formed on Vulkollan or Adiprene rollers, or if initial signs that the outer section is disengaging from the core appear - increased bearing play occurs due to worn ball bearings - significant lubrication leakage is seen - the rollers do not run smoothly
Buffers	<ul style="list-style-type: none"> - cracks, breaks or embrittlements are seen
Center plates and side shields	<ul style="list-style-type: none"> - corrosion protection has failed
Cable supports	<ul style="list-style-type: none"> - corrosion protection has failed - initial signs of cracks in the supports are seen - the riveting nut does not provide sufficient clamping for the cable clamp/cables
Fasteners	<ul style="list-style-type: none"> - corrosion protection has failed - connection integrity (screw joints, clamp connections, glued connections) is no longer ensured
Cables	<ul style="list-style-type: none"> - wire, shielding or jacket breakage is seen - corkscrews have formed
Cable clamps	<ul style="list-style-type: none"> - corrosion protection has failed - cracks and embrittlements are seen in the clamp rubber - the clamp does not hold cables sufficiently
Towing rope	<ul style="list-style-type: none"> - wires break, structural changes occur, corrosion and abrasion
Towing devices	<ul style="list-style-type: none"> - corrosion protection has failed - the towing arm window is deformed - cracks in the welding joints appear

Festoon Systems for I-Beams Program 0350 / 0360 / 0364

Component	Wear limit has been reached if
End clamp	<ul style="list-style-type: none">- corrosion protection has failed- attachment to the track beam is no longer secure
Damping device and shock cords	<ul style="list-style-type: none">- corrosion protection has failed- severe constrictions in the shock cords occur- the mantle of the shock cord is even partially torn- fraying strands on the shock cord appear- mechanical deformations appear on the shock cord brackets
Track beam	<ul style="list-style-type: none">- corrosion protection has failed- significant tracks from the rollers of the cable trolley system appear

8.2.8 Repeat inspections



- Devices and systems are to be periodically inspected by an expert. In general, visual and functional checks are to be performed. The condition of components with regard to damage, wear, corrosion or other damage is to be determined. Generally speaking, the completeness and functionality of the safety equipment is evaluated. To better evaluate the wear and tear of parts, disassembly may be required.
- All regular inspections are to be performed by the operator.

Every operator is to record all inspection, service and maintenance tasks in a machine book in an orderly manner. This is to be confirmed by a technical expert. In case of inaccurate or missing entries, the warranty is rendered null and void.

8.2.9 Repair

Request a customer service technician from Conductix-Wampfler for all repairs.

If qualified service technicians from the system operator perform the repairs themselves, all information contained in these operating instructions must be observed.

Conductix-Wampfler accepts no liability or responsibility for damages and production faults that result from failure to follow these operating instructions.

For maintenance and repair, only use

- suitable tools in good working order
- only original replacement parts from Conductix-Wampfler or replacement parts explicitly authorized by Conductix-Wampfler.

9 Troubleshooting



WARNING!

Danger of injury due to improper troubleshooting!

Improper troubleshooting can result in serious injury to person and property.

- Contact the manufacturer in case of malfunction.
- Allow troubleshooting to be carried out only by personnel from or authorized by the manufacturer.



CAUTION!

Improper use can result in serious injury to person and property.

Elimination of faults may only be performed by qualified specialists.

Faults	Cause	Solution
Towing rope torn	Overstress Wear ¹⁾	Exchange towing rope
Shock cord torn	Overstress Wear ¹⁾	Exchange shock cord
Buffer is defective	Overstress Wear ¹⁾	Exchange buffer
Roller function impaired	Overstress Wear ¹⁾	Exchange roller
Noticeable mechanical strain of the components (bending, tear, wear)	Malfunction ²⁾	Exchange the corresponding component

¹⁾ The cause of overstress must be identified and corrected.

²⁾ If injury to person and property can occur during breakdowns then Conductix-Wampfler must be informed immediately.

10 Disassembly and disposal

10.1 Safety



WARNING!

Danger of injury due to improper disassembly!

Stored energy, sharp components, points, and edges on and in the festoon system or the tools needed can cause injury.

- Before starting work, ensure sufficient space.
- Handle open, sharp-edges components carefully.
- Maintain order and cleanliness in the work area! Loosely stacked or scattered components and tools are a source of accidents.
- Dismount components properly. Note the high weight of some components. If necessary, use lifting gear.
- Secure components so that they cannot fall or fall over.
- Involve the manufacturer in case of any unclear points.



WARNING!

Danger of injury from moving components!

Incautious handling of the festoon system can lead to severe injury or damage to the festoon system.

- Be sure that the festoon system does not start by itself.
- While it is moving, do not reach into moving parts, particularly the interface between the buffer and buffer plate.
- Block off the dangerous area under the system.



CAUTION!

Danger of tripping on projecting parts!

When working on the festoon system, there is a risk of tripping.

- When walking in the work and danger area, be careful of projections and depressions in the floor. No loose objects may be left on the floor.



WARNING!

Danger of crushing!

When moving the festoon system, there is a danger of crushing limbs between the buffer and buffer plate, as well as between the running gear and the track beam.

- When the system is moving, do not enter the danger area of the festoon system.



WARNING!

Danger of crushing!

During disassembly of the festoon system, there is a danger of crushing limbs between load carrier and the track beam.

- During disassembly, do not enter the danger area of the festoon system.

Mounting Instructions

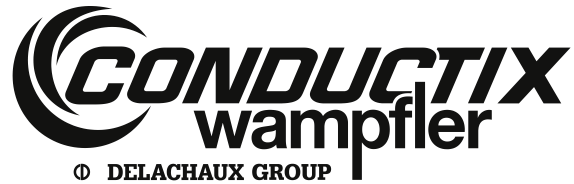

Festoon Systems for I-Beams

Program 0350 / 0360 / 0364

10.2 Disassembly

After the system is no longer in use, the festoon system must be disassembled and environmentally friendly disposal carried out.

Before starting disassembly:

- Remove operating and auxiliary materials as well as residual processing material, and dispose of them in an environmentally appropriate manner.

Then clean the assemblies and components properly and disassemble them as required by applicable local workplace safety and environmental protection regulations.

Personnel:

- May only be carried out by trained technicians
- At least two people

Tools needed:

- Crescent wrench
- Securing tool



CAUTION!

→ Loads are to be carefully fastened onto suitable hoists or load-carrying devices that are technically intact and have sufficient load capacity.

10.3 Disposal

Properly disassembled components are to be recycled if no return or disposal agreement has been made.

- Scrap metals.
- Take plastic elements for recycling.
- The other components are to be disposed of according to their material composition.



CAUTION!

Environmental damage due to improper disposal!

Electrical waste, electronic components, lubricants, and other auxiliary materials are subject to hazardous waste disposal regulations and may only be disposed of by authorized specialists.

Local community officials or special disposal companies can provide information about environmentally appropriate disposal.

Festoon Systems for I-Beams Program 0350 / 0360 / 0364

10.4 Documentation for electrical equipment

See separate electrical documentation.

10.5 Spare parts list



NOTICE!

Keeping a stock of the most essential spare and wear parts at the place of installation ensures constant operational readiness of the system.



CAUTION!

Safety risk due to wrong spare parts!

Wrong or faulty spare parts can result in damages, malfunctions or complete failure as well as impair safety.

→ Use only original spare parts of the manufacturer!

No liability is accepted or warranty given for damages that occur from the use of unauthorized spare parts and accessories.

For spare part orders, please indicate the following data:

- Order no. (see type plate on the end clamp)
- Model name (see type plate on the end clamp)
- Part no. (see spare parts list in order documentation)
- Description
- Unit count
- Desired mode of shipping (postal, freight, sea, air, express)
- Shipping address

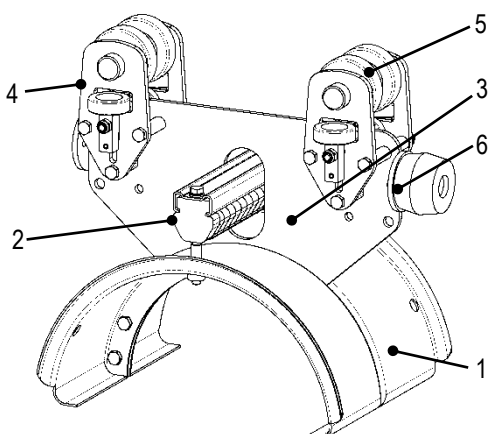

Fig. 44: Cable trolley

■ Available spare parts are:

- 1) Cable support, complete with clamping bar and mounting elements
- 2) Clamping bar complete with C-rails and mounting elements
- 3) Complete trolley
- 4) Side shield complete with rollers
- 5) Main rollers, horizontal guide rollers and anti-lift rollers
- 6) Buffer

The exact replacement part name can be found in the project-specific replacement parts list.

Mounting Instructions



Festoon Systems for I-Beams Program 0350 / 0360 / 0364

10.6 Product observations

We strive to observe our products after delivery in order to further improve them and better meet your needs. Please use the form on the following pages to communicate your experiences and issues with us that could be of interest for our improvement process. Thank you very much for your help.

Please fax the filled out form to: ++49 7621 662 284

For example

- changed configuration data
- experiences with the festoon system
- recurrent errors
- difficulties with documentation

Your contact data

Company:	Customer No.:
<hr/>	
Department:	
Contact Person:	
Address:	Zip code
PO Box	
City	
Phone	Fax:
Email:	

Your experiences and observations:

Mounting Instructions



Festoon Systems for I-Beams Program 0350 / 0360 / 0364

11 Final Acceptance Certificate (PFR05-15-02-E)

Customer:	Customer No.:
	Purchase No.:
	CXW Order No.:
	CXW Assembly Order No.:

Installation Site	Project Name/ Installation Site:	
	Address:	
	Post code:	City:
	Contact person / Phone no.:	Meeting point:

Start of installation (on-site):	End of installation (on-site):
----------------------------------	--------------------------------

Needed installation time (in h):	Needed travel time (in h):
----------------------------------	----------------------------

The installation of above mentioned project has been completed today by Conductix-Wampfler and meets all requirements for final acceptance. From today, the risk is transferred to the customer

The acceptance has been confirmed on a separate customer specific acceptance protocol. yes
Enclosure:

Maintenance instructions have been handed over: yes
CE-label is fixed: yes

Following works were performed:

Following works, included in the order, were not performed:

Customer Claims:

Supplier claims (CXW):

Installation supervisor supplier (Conductix-Wampfler)		Installation supervisor customer	
Name:		Name:	
Date:	Signature:	Date:	Signature:

Mounting Instructions

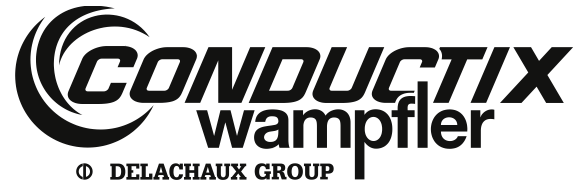

Festoon Systems for I-Beams

Program 0350 / 0360 / 0364

Conductix-Wampfler GmbH
Rheinstrasse 27 + 33
79576 Weil am Rhein - Maerkt
Germany

Phone: +49 (0) 7621 662-0
Fax: +49 (0) 7621 662-144
info.de@conductix.com
www.conductix.com